



CUSTOM

SC WORKTOP REFRIGERATOR MODEL 51000PT-513

Self-contained refrigerated worktop unit with 16 gauge reinforced stainless steel top. Stainless steel doors on concealed hinges. CFC free, R-513a refrigeration system. Evaporator blower coil with expansion valve supplied and installed. 6" high adjustable and movable legs.

AVAILABLE MODELS:

- 51347PT3-513
- 51368PT3-513
- 51347PT5-513
- 51368PT5-513

STANDARD FEATURES:

- Available under one piece top with other modular equipment up to 16' in length
- 6" high legs—adjustable and movable
- Foamed in place "CFC free" urethane insulation
- Side mounted compressor with mullion "Turbo" coil provides balanced cooling throughout the interior space
- SNAP compliant R-513a "CFC free" refrigerant
- Automatic condensate evaporator

CABINET EXTERIOR: Top to be one piece of die-formed 16 gauge stainless steel with 2 1/2" nosing. Ends at top fitted with recessed heavy duty steel bars for field bolting units together, producing a hairline seam. Hinged louver panel to be stainless steel. Exterior body to be corrosion resistant steel. Door opening frames are ABS and contain magnetic strip for positive seal of door gaskets. Work surface to be at 36" work height. Legs to be 6" high stainless steel with adjustable bullet foot. Legs mounted to full length channel frame assembly which is integrally welded to bottom of body assembly. Legs can be moved left to right to avoid floor obstacles during installation.

CABINET INTERIOR: Base interior to be all stainless steel bottom, side walls and interior ceiling. Door opening/jam to be thermal-formed ABS which minimizes sweating and is easy to clean. One baked enamel finished shelf provided behind each door. Unit insulation to be CFC free foamed in place urethane.

DOORS: Door fronts to be 22-gauge stainless steel exterior front with 16 gauge stainless steel door pulls/handles. The interior liner is vacuum formed ABS with integral gasket retainer for easy cleaning and accepts Randell's Exclusive Press Fit Gasket system. Doors are mounted on concealed hinges.

REFRIGERATION: The refrigeration systems will utilize SNAP compliant "CFC free" R513a refrigerant with (0) ozone depletion (ODP) and (631) global warming potential (GWP). Refrigeration system to include condensing unit and control for field adjustability. Compressor housing to allow maximum airflow and permit mounting of standard condensate evaporator. Mullion coil, is coated to resist corrosion, and offers maximum air flow while allowing use of the full depth interior accessible from each side of the unit. Unit is totally prewired and supplied with 8' cordset (NEMA 5-15P) for 115V operation.

ORIGIN OF MANUFACTURE: Designed and manufactured in the United States.

PROJECT NAME:

LOCATION:

ITEM NO:

QTY:

MODEL NO:

AIA NO:

SIS NO:

CSI SECTION: 11400

Model 51368PT5-513 shown with optional stainless steel ends.



OPTIONS/ACCESSORIES:

- Patented Drawer Cartridge Systems - Exclusive Randell Feature + 3 years parts & labor warranty
- Tray racks for sheet pans
- Stainless Steel Ends
- Laminate fronts, ends options
- Casters in lieu of legs
- Over-shelving storage options
- Compressor on right option

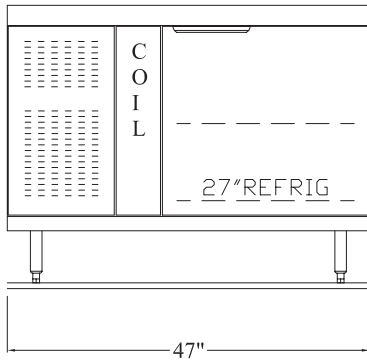

51347PT3/5-513

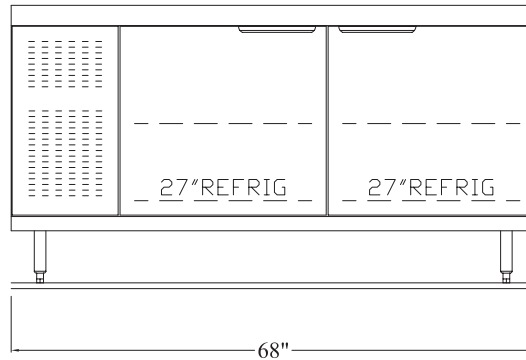

51368PT3/5-513

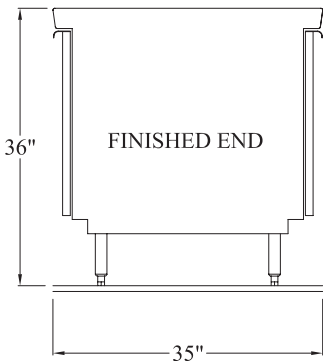

51347PT3-513 & 51368PT3-513

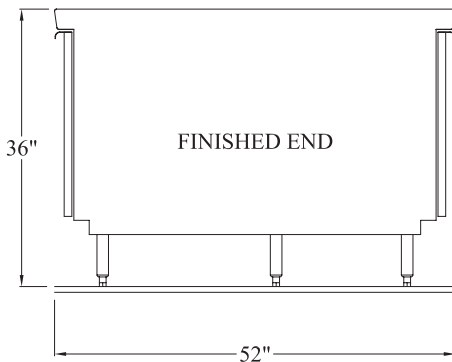

51347PT5-513 & 51368PT5-513

51000PT-513 SERIES (COMPRESSOR LEFT) SELF-CONTAINED REFRIGERATORS WITH STAINLESS STEEL TOPS

Model	51347PT3-513	51368PT3-513	51347PT5-513	51368PT5-513
Length	47"	68"	47"	68"
Depth	35"		52"	
Height	36"			
# of 27" Doors	1/side, 2 total	2/side, 4 total	1/side, 2 total	2/side, 4 total
Door Clearances	22.25" (left to right) 20.25" (top to bottom)			
Interior Depth Behind Door	26"		43"	
Min. Compr. Hsg.	14"			
Storage Cu. Ft.	8.14	14.97	15.44	27.44
H.P./Refrigerant	1/4HP/513A			
Amps	6.6			
Volt/Cycle/Phase	115/60/1			
NEMA	5-15P			
Ship Wt. lbs	268	344	336	439