



# CAPKOLD® COOK-CHILL SYSTEMS

## PASTA COOK KETTLE MODEL N-P

CapKold® hemispheric bottom steam jacketed pasta kettle, with integrated water wash system and overflow drains, for the rapid cooking, washing, starch removal and cooling of pasta. Pasta cook kettle may be operated manually without a control panel.

PROJECT NAME:

LOCATION:

ITEM NO:

QTY:

MODEL NO:

AIA NO:

SIS NO:

### AVAILABLE MODELS:

- N-50P (50 GALLON)
- N-100P (100 GALLON)
- N-150P (150 GALLON)
- N-200P (200 GALLON)

### CONSTRUCTION

- Hemispheric bottom jacket is designed for operation up to 90 PSI maximum pressure and built to ASME code, and National Board registered. Kettle will operate dependably between 15 PSI and 90 PSI
- 316 stainless steel interior, type 304 elsewhere
- Spiral baffle for efficient cold water jacket cooling
- Two side mounted overflow drains mounted at kettle rim and provided with stainless vertical drain piping
- Manual 3/4" cold water inlet in kettle for rapid introduction of water for product cooling and starch rinse
- Interior and exterior of kettle finished to No. 4 Sanitary Finish
- 3" manual sanitary ball valve outlet
- Stainless steel legs with adjustable stainless steel floor mounting flanges
- 3/4" swing spout water fill faucet
- Manufactured to latest sanitary standards and HACCP compliant
- Steam valve and condensate trap supplied for manual operation
- NSF listed

### CONTROL SYSTEMS:

- All kettle control valves necessary for manual kettle operation
- Factory mounted safety relief valve supplied

### NOTES:

- Recommend 50-90 PSI steam for optimal cooking

**ORIGIN OF MANUFACTURE:** Designed and manufactured in the United States.

CKNP Pasta Cook Kettle - Optional Pre-Piped Box Shown



### OPTIONS/ACCESSORIES:

- Attached prepiped control valve box
- Gallon Master automatic water metering system
- Hot water to faucet
- 3" air operated drop down valve
- Flush mounted temperature sensor (Control panel required)
- Prison Package
- Kettle control panel (See Specification CKCP) requires kettle valve box
- Pasta Baskets
- Hoists and rail systems (See Specifications CKH and CKPB)

**CapKold Kettles**  
**CKNP 160387 RevA**  
Revised 10/13



160388 REV A

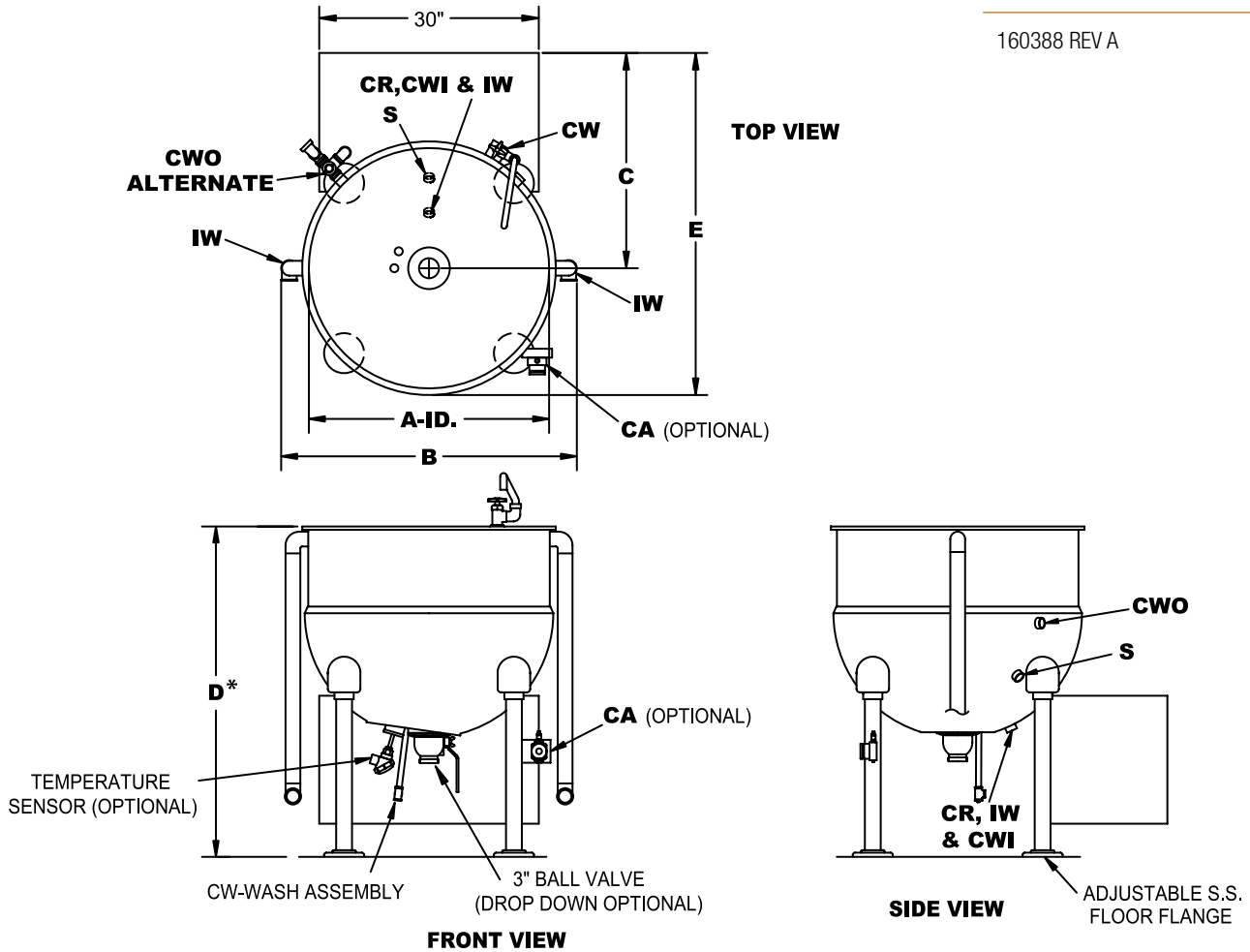

**PHYSICAL DIMENSIONS**

MODEL	A	B	C	D*	E	RECOMMENDED CLEARANCES		
						RIGHT	LEFT	REAR
N-50	30"	40"	35"	44.5"	51"	12"	12"	12"
N-100	36"	46"	38"	49.5"	57"	12"	12"	12"
N-150	42"	52"	41"	52.5"	63"	12"	12"	12"
N-200	48"	58"	44"	55.5"	69"	12"	12"	12"

\* Additional heights available, contact factory.

**UTILITY CONNECTIONS (ALL MODELS)**

SYMBOL	CA (OPTIONAL)	HW	CW	COOLING	COOLING	CR	IW	S
<b>DESCRIPTION</b>	COMPRESSED AIR INLET	HOT POTABLE WATER INLET	COLD POTABLE WATER INLET	ICE WATER INLET	ICE WATER OUTLET	CONDENSATE RETURN	INDIRECT WASTE	STEAM INLET
<b>CONNECTION</b>	1/4" NPT	3/4" NPT	3/4" NPT	3/4" NPT	3/4" NPT	3/4" NPT	3/4" NPT	1" NPT

**UTILITY REQUIREMENTS**

MODEL	COMPRESSED AIR 90 PSI MIN.	POTABLE WATER	COOLING WATER	INDIRECT WASTE	STEAM 15-90 PSI MAX	WEIGHTS (lbs.)			
						SHIPPING	OPERATING	W / PIPING BOX OPTION SHIPPING	OPERATING
N-50	1 CFM @ 80-90 PSI	10 GPM	15 GPM	1 GAL/BATCH	430 lbs/hr @ 90 PSI	550	835	750	985
N-100	1 CFM @ 80-90 PSI	10 GPM	15 GPM	2 GAL/BATCH	700 lbs/hr @ 90 PSI	625	1345	825	1500
N-150	1 CFM @ 80-90 PSI	10 GPM	15 GPM	3 GAL/BATCH	1200 lbs/hr @ 90 PSI	685	1820	885	700
N-200	1 CFM @ 80-90 PSI	10 GPM	15 GPM	3 GAL/BATCH	1400 lbs/hr @ 90 PSI	885	2400	1005	2550