



CUSTOM

SC RECESSED COLDWALL REFRIGERATOR MODEL 51000PO

Self-contained refrigerator storage units with mechanically cooled pan opening. These units are offered in variety of lengths to meet your specific base storage or pan storage requirements. The mechanically cooled pan opening uses Randell's exclusive design technologies, such as our Exclusive Refrigerated Pan Opening Thermostat allowing customers to make adjustments to the opening temperatures (independent of the base).

PROJECT NAME:

LOCATION:

ITEM NO:

QTY:

MODEL NO:

AIA NO:

SIS NO:

CSI SECTION: 11400

AVAILABLE MODELS:

- 51341PO
- 51344PO
- 51347PO
- 51356PO
- 51359PO
- 51362PO
- 51365PO
- 51368PO
- 51377PO
- 51380PO
- 51383PO
- 51386PO
- 51389PO
- 51395PO
- 513114PO
- 513126PO

STANDARD FEATURES:

- Low profile 2" recess pan design provides easy reach and optimal pan temperatures & reliability
- Full Length Poly Cutting Board
- Front breathing compressor housing with directed air flow - A Randell Exclusive.
- Easy maintenance Press-Fit gaskets - A Randell Exclusive
- Pan opening thermostat- A Randell Exclusive
- Drain in pan opening for easy cleaning
- Hinged louver for easy access
- Hinged removable stainless steel covers
- Foamed in place urethane insulation providing superior insulation and durability
- 6" high adjustable legs, moveable left to right if needed
- Available up to 16' under one common assembly
- Adapter bars are standard to accommodate a compliment of 1/6 size pans
- Front breathing louver design allows sealing to wall & curb mounting without special requirements

CABINET EXTERIOR: Top to be one piece of die-formed 16 gauge stainless steel with 2 1/2" nosing Backsplash to be coved cornered, with 45° return at top and overall height of 6 3/4". Ends at top fitted with recessed heavy duty steel bars for field bolting units together, producing a hairline seam. Hinged louver panel to be stainless steel. Exterior body to be corrosion resistant steel. Door opening frames are ABS and contain magnetic strip for positive seal of door gaskets. Work surface to be at 36" work height. Legs to be 6" high stainless steel with adjustable bullet foot. Legs mounted to full length channel frame assembly which is integrally welded to bottom of body assembly. Legs can be moved left to right to avoid floor obstacles during installation.

CABINET INTERIOR: Base interior to be ABS thermoplastic at ends only. Stainless steel interior liner to be coved cornered to form bottom, back and top. Unit insulation to be CFC free foamed in place urethane.

DOORS: Door fronts to be 22-gauge stainless steel exterior front with 16 gauge stainless steel door pulls handles. The interior liner is vacuumed formed ABS with integral gasket retainer for easy cleaning and accepts Randell's Exclusive Press Fit Gasket System. Doors are mounted on concealed hinges.

REFRIGERATION: System is a balanced heavy duty R-404A refrigerant system with an energy efficient automatic defrost (for base evaporator coil). The base is cooled by an independent blower coiled operating on its own expansion valve and thermostat and operates through a dedicated solenoid valve. The rail is provided with a pressure control to operate the condensing unit on demand and a rail thermostat (located in the compressor housing) making it easily adjustable for specific ambient conditions without effecting the balance of the system. An on/off switch for the rail is located behind the hinged louver panel.

ORIGIN OF MANUFACTURE: Designed and manufactured in the United States.

SC Recessed Coldwall Refrigerator. Model 51362PO shown with optional finished end.



OPTIONS/ACCESSORIES:

- Hinged slide back cover
- Lift-off (removable) night covers
- Stainless Steel Ends
- Stainless Steel Back
- Laminate fronts, ends and back options
- Casters in lieu of legs
- Over-shelving storage options
- Wide pan opening

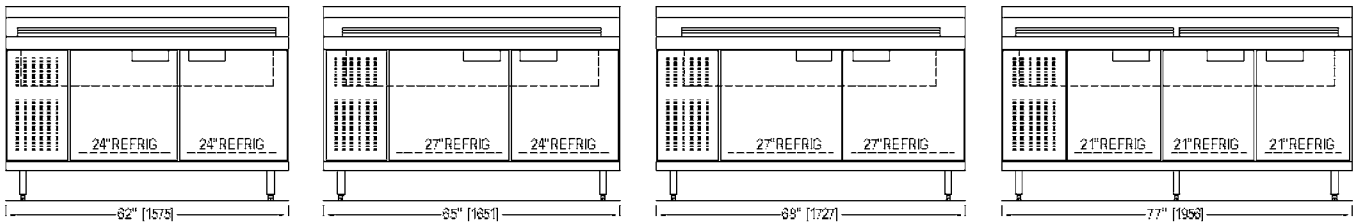
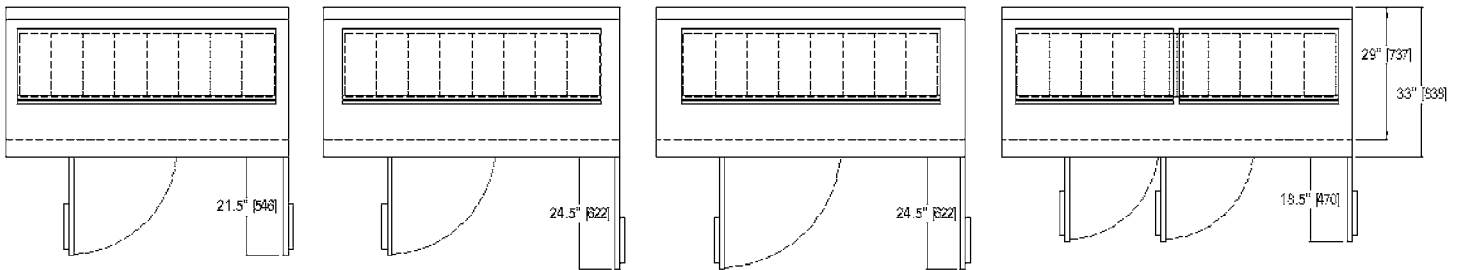
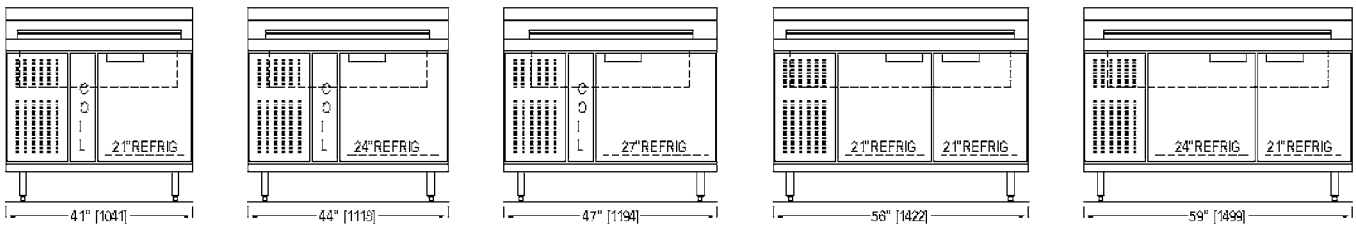
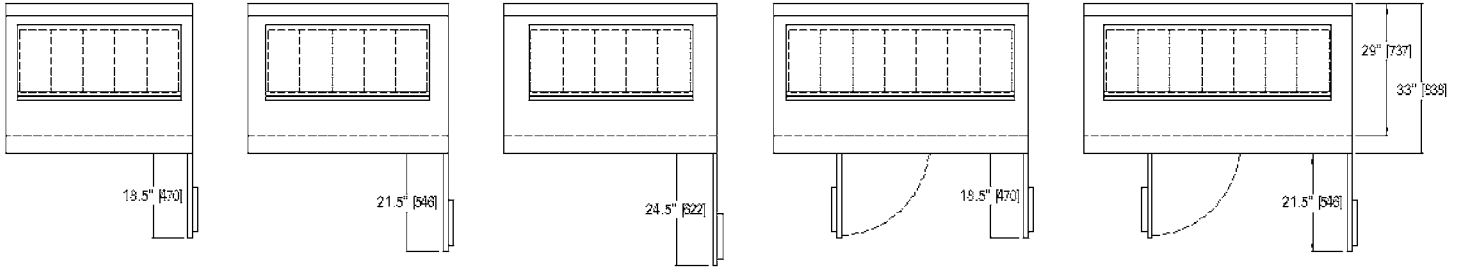

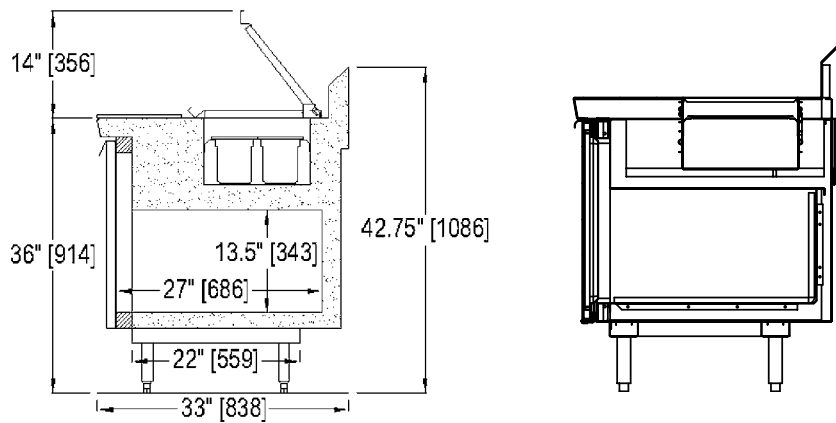
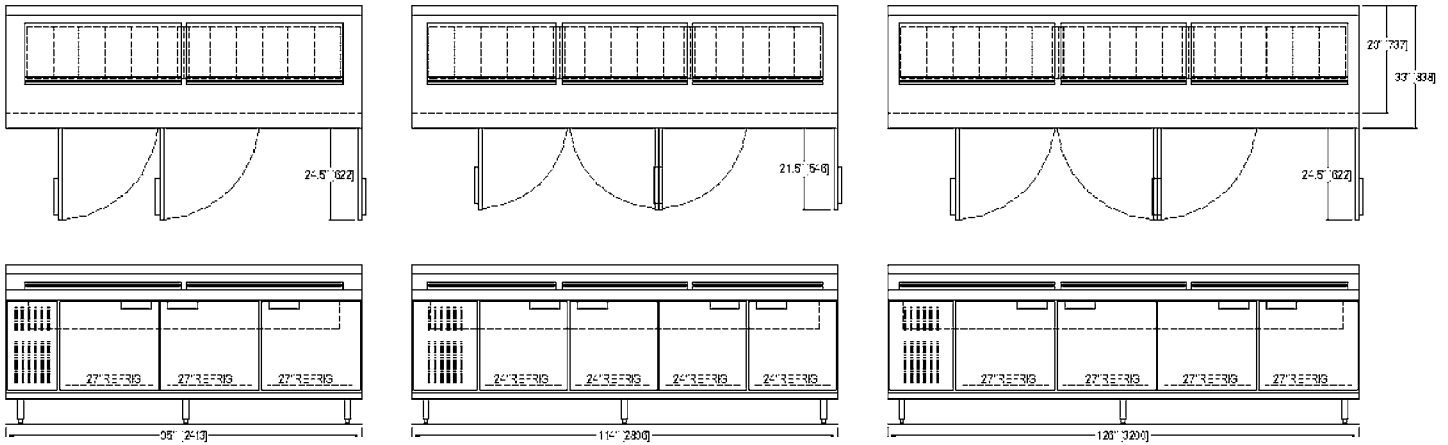
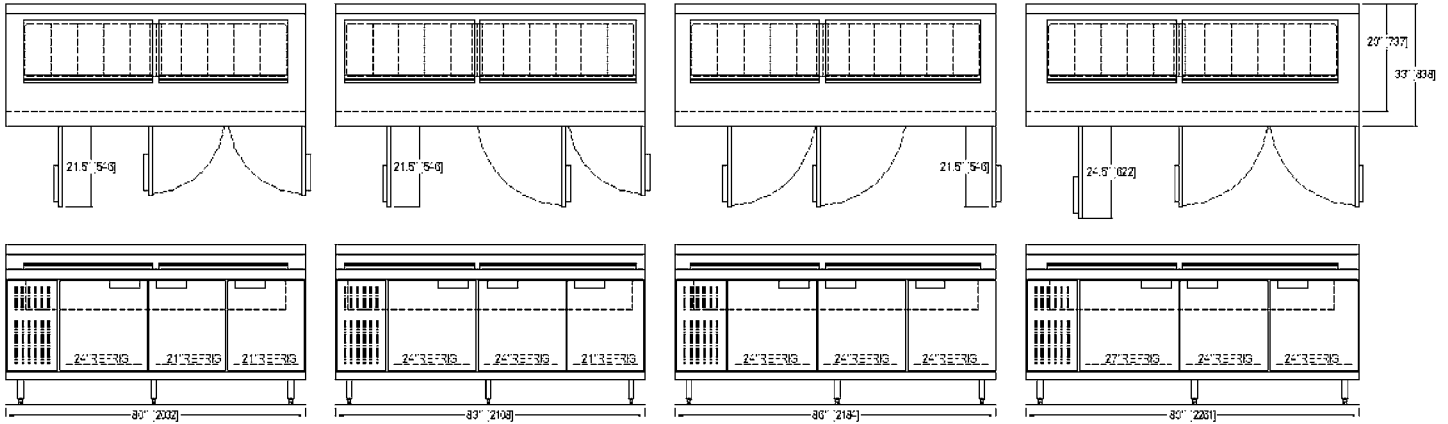



51000PO SERIES (COMPRESSOR LEFT) SELF-CONTAINED REFRIGERATORS WITH STANDARD DEPTH RECESSED PAN OPENING								
Length	41"	44"	47"	56"	59"	62"	65"	68"
Model 33"	51341PO	51344PO	51347PO	51356PO	51359PO	51362PO	51365PO	51368PO
#of Doors	(1) 21" + 6" coil hsg.	(1) 24" + 6" coil hsg.	(1) 27" + 6" coil hsg.	(2) 21"	(1)21" (1)24"	(2) 24"	(1)24" (1)27"	(2) 27"
Min. Compr. Hsg.	14"	14"	14"	14"	14"	14"	14"	14"
# Pans	(6-10) 1/6	(6-10) 1/6	(6-10) 1/6	(6-14) 1/6	(8-14) 1/6	(8-16) 1/6	(8-16) 1/6	(8-16) 1/6
Min. Length of Opening	27"	27"	27"	27"	34"	34"	34"	34"
Storage Cu. Ft.	4.31	4.99	5.67	7.71	8.39	9.07	9.75	10.43
Cutting Board Width	10" wide	10" wide	10" wide	10" wide	10" wide	10" wide	10" wide	10" wide
H.P./Refrigerant	1/3hp/134a	1/3hp/134a	1/3hp/134a	1/3hp/134a	1/3hp/134a	1/3hp/134a	1/3hp/134a	1/3hp/134a
Amps	9.0	9.0	9.0	9.0	9.0	9.0	9.0	9.0
Volt/Cycle/Phase	115/60/1	115/60/1	115/60/1	115/60/1	115/60/1	115/60/1	115/60/1	115/60/1
NEMA	5-15P	5-15P	5-15P	5-15P	5-15P	5-15P	5-15P	5-15P
Ship Wt.- lbs	418	435	451	495	512	528	545	561
BTU Design load	294/262	294/283	353/304	412/445	412/467	470/488	470/509	529/531
BTU System Cap.	1109/2141	1109/2141	1201/2141	1283/2141	1283/2141	1356/2141	1356/2141	1423/2141

51000PO SERIES (COMPRESSOR LEFT) SELF-CONTAINED REFRIGERATORS WITH STANDARD DEPTH RECESSED PAN OPENING (cont.inued)								
Length	77"	80"	83"	86"	89"	95"	114"	126"
Model 33"	51377PO	51380PO	51383PO	51386PO	51389PO	51395PO	513114PO	513126PO
#of Doors	(3)21"	(2)21" (1)24"	(2)24" (1)21"	(3) 24"	(2)24" (1)27"	(3)27"	(4) 24"	(4) 27"
Min. Compr. Hsg.	14"	14"	14"	14"	14"	14"	18"	18"
# Pans	(10-18) 1/6	(10-18) 1/6	(10-20) 1/6	(10-20) 1/6	(10-20) 1/6	(12-20) 1/6	(14-26) 1/6	(14-30) 1/6
Min. Length of Opening	41"	41"	41"	41"	41"	41"	55"	55"
Storage Cu. Ft.	12.47	13.15	13.83	14.51	15.19	16.55	19.95	21.76
Cutting Board Width	10" wide	10" wide	10" wide	10" wide	10" wide	10" wide	10" wide	10" wide
H.P./Refrigerant	1/2hp/134a	1/2hp/134a	1/2hp/134a	1/2hp/134a	1/2hp/134a	1/28hp/134a	5/8hp/404a	3/4hp/404a
Amps	12	12	12	12	12	12	12.8	12.8
Volt/Cycle/Phase	115/60/1	115/60/1	115/60/1	115/60/1	115/60/1	115/60/1	115/60/1	115/60/1
NEMA	5-15P	5-15P	5-15P	5-15P	5-15P	5-15P	5-20P	5-20P
Ship Wt.- lbs	611	627	644	660	693	726	809	875
BTU Design load	588/671	588/693	647/714	647/735	706/757	764/799	882/983	1000/1068
BTU System Cap.	1866/3319	1866/3319	1966/3319	1966/3319	2061/3319	2151/3319	2735/3946	3330/6435

NOTE: Pan capacity reflected is the actual amount of pans that are clearly accessible by the operator. Units with multiple covers may actually have additional pan capacity that is partially obstructed by the cover divider/mullion.

BTU load and capacity ratings based on 86F ambient.

DOOR OPENING SIZES			
DOOR WIDTH	CLEARANCES THROUGH DOOR		INTERIOR DEPTH BEHIND DOOR
	LT. TO RT.	TOP TO BOTTOM	(unit depths in parentheses)
18"	13 1/4"	13 1/2"	(33")-26" (29")-22" (22")-15.5"
21"	16 1/4"	13 1/2"	(33")-26" (29")-22" (22")-15.5"
24"	19 1/4"	13 1/2"	(33")-26" (29")-22" (22")-15.5"
27"	22 1/4"	13 1/2"	(33")-26" (29")-22" (22")-15.5"

•Shelf depth is 25 1/4" on 33" deep equipment, 21 1/4" on 29" deep equipment, and 14 1/2" on 22" deep equipment.