



# DROP-IN

## FREEZER/PLATE CHILLER MODEL 9550-290 & 9552-290

Drop-in self-contained freezer with stainless steel top, raised rim opening, and insulated lids. Units can be installed in two airflow directions to provide proper cooling, dependent of application. R-290 refrigerant, "CFC free". Wrapped refrigeration construction with condensing unit, and electronic control. Cordset for 115V operation. All Drop-In cold pans include our easy to use hold down brackets. The Randell designers have redesigned the brackets, making it easy to install the cold pan to any counter top.

PROJECT NAME:

LOCATION:

ITEM NO:

QTY:

MODEL NO:

AIA NO:

SIS NO:

CSI SECTION: 11400

### AVAILABLE MODELS:

- 9550-290
- 9552-290

### STANDARD FEATURES:

- Self-contained refrigeration system with electronic control, system utilizes "CFC free", R-290 refrigerant
- Choice of front or side airflow
- Coved cornered interior
- Stainless steel top with insulated hinged covers that can be rotated (9552-290 model only), allowing a front-back opening or a left-right opening, regardless of how you install the unit for airflow. Optional clear plexi covers available on request.
- Self-contained freezer suitable for ice cream, frozen foods, plate and mug chilling
- 8' cordset provided
- Hold down clips on two sides, with additional mounting holes

**UNIT EXTERIOR:** Top to be one piece 18 gauge stainless steel. Top to have opening with raised rim, fitted with removable, hinged, insulated lid. Body exterior to be corrosion resistant steel. Condensing unit mounted on corrosion resistant framework, placed below unit body. New hold down clips. Stainless steel louver panel provided for field installation in counter.

**UNIT INTERIOR:** Interior to be stainless steel, with coved corner construction for easy cleaning. Insulation to be CFC free, foamed in place polyurethane. Unit interior sides wrapped with refrigerating lines.

**REFRIGERATION:** CFC free, R-290 refrigeration system to be wrapped refrigeration construction. Condensing unit, and electronic control for operator adjustability mounted just inside corrosion resistant framework, placed below unit body. 8' cordset (NEMA 5-15P) supplied for 115V operation.

This equipment is intended for use in rooms having an ambient temperature of 86°F (30°C) or less.

**AIR FLOW:** Units can be installed in two airflow directions to provide proper cooling, dependent of application. Front/back airflow shown at right.

Model 9550-290  
left/right airflow:

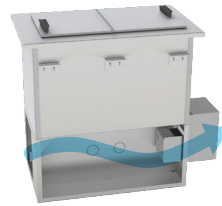

Model 9552-290  
left/right airflow:

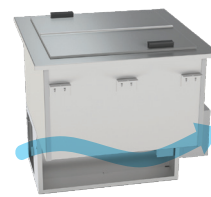

Model 9550-290  
right/left airflow:



Model 9552-290  
right/left airflow:



Drop-in self-contained freezer with stainless steel top, raised rim opening, and insulated lids.

Model 9550-290 back to front airflow:



Model 9552-290 back to front airflow:



**ORIGIN OF MANUFACTURE:** Designed and manufactured in the United States.



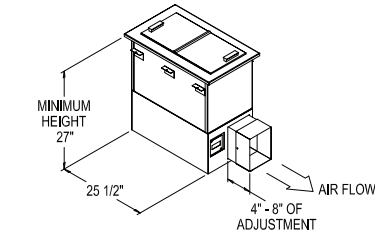

COVER CAN BE ROTATED 90° AS PER APPLICATION

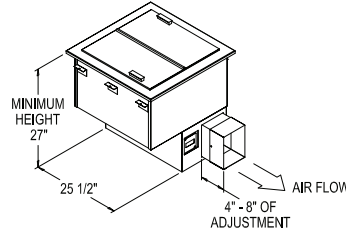

**Recommended Installation Instructions For Self-Contained Freezers:**

1. Secure unit to top and seal with "NSF" approved silicone
2. Install inside duct with thumb screws and adjust outside duct to fit between condenser coil and counter's louvered cutout
3. Secure outside duct in place with screws thru pre-punched holes

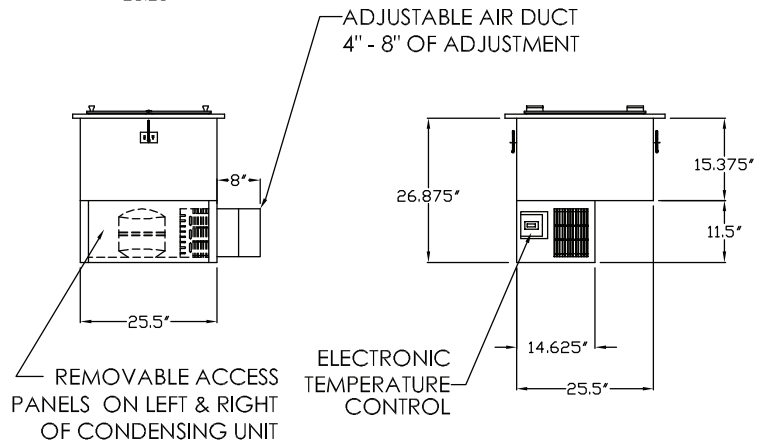
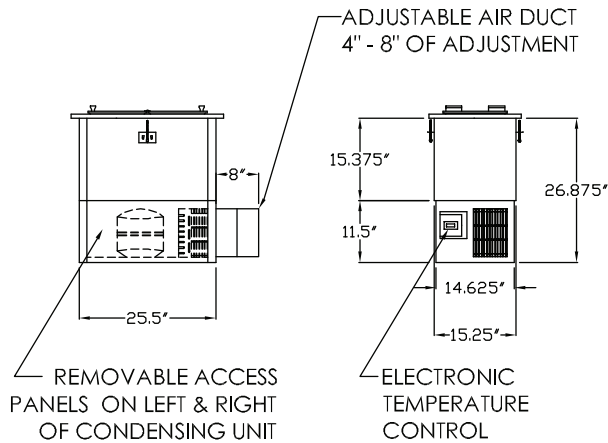
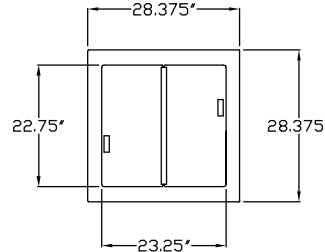
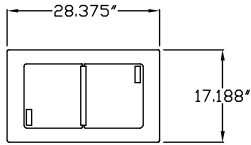
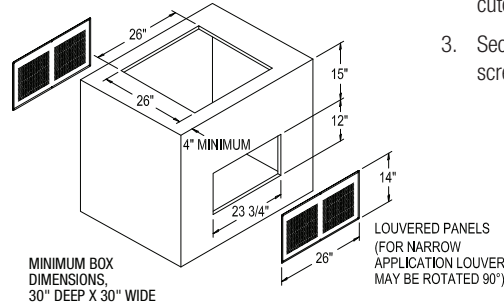
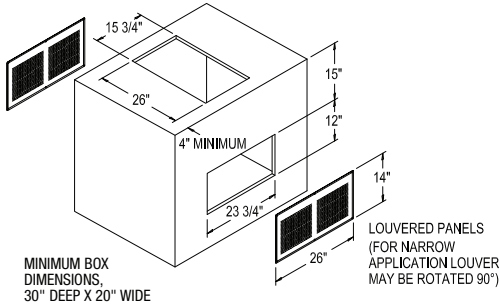

MODEL 9550A

MODEL 9552A

Model	L	D	No. of Openings	Storage Cu. Ft.	Gallon Capacity	Counter Cutout Dim.	Power Usage kW (per day)	H.P.	Volt	Amp.	NEMA	Ship Wt.
9550-290	28 3/8"	17 3/16"	1	1.8	6	26"x15.75"	.95	1/4	115/60/1	2.0	5-15P	125
9552-290	28 3/8"	28 3/8"	1	3.36	11.2	26"x26"	1.34	1/4	115/60/1	2.0	5-15P	165