



SERVING LINES, FIBERGLASS

TRAY AND SILVERWARE STAND MODEL SW

Randell's SW Stainless Steel Top Tray & Silverware Stand designed for virtually any tray & silverware application, the SW series is enclosed in brilliant one-piece fiberglass body and stainless steel top.

PROJECT NAME:

LOCATION:

ITEM NO:

QTY:

MODEL NO:

AIA NO:

SIS NO:

CSI SECTION: 11400

AVAILABLE MODELS:

- | | |
|---------------------------------------|---------------------------------------|
| 14 GAUGE TOP: | 16 GAUGE TOP: |
| <input type="checkbox"/> 14GFG SW-8 | <input type="checkbox"/> RANFG SW-8 |
| <input type="checkbox"/> 14GFG SW-12 | <input type="checkbox"/> RANFG SW-12 |
| <input type="checkbox"/> 14GFG SW-8PS | <input type="checkbox"/> RANFG SW-8PS |

AVAILABLE FIBERGLASS COLORS:

- Pitch Black
- Dark-Bark Brown
- Cabernet Wine
- British Racing Green
- Tin Man Gray
- True Blue
- Light Sky Blue
- Candy Apple Red
- Tiger Lilly Orange
- Canary Yellow
- White

STANDARD FEATURES:

- Concealed locking mechanism with easy to use spring-activated catch
- Adaptor plate top allows flexibility to use a variety of bin applications

CABINET CONSTRUCTION: One-piece molded fiberglass body for smooth exterior finish. All corners and areas where accessories are mounted are reinforced internally with metal backers.

TOP CONSTRUCTION: Exterior top is standard in reinforced 14 or 16 gauge 300 series stainless steel with #4 finish.

ORIGIN OF MANUFACTURE:

Designed and manufactured in the United States.

Serving Lines, Fiberglass Tray and Silverware Stand. Model 14GFG SW-8PS shown with optional kick plate.



OPTIONS/ACCESSORIES:

- Canopy
- Overshelves
- Trayslides
- Corian top
- Kick Plate
- Graphics
- Sneeze Guards
- Elementary School Height
- Electrical Distribution System

Drawings are to be viewed in the same order as the chart

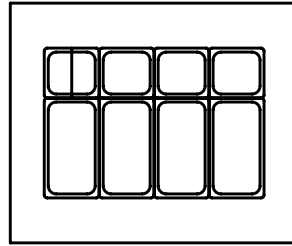
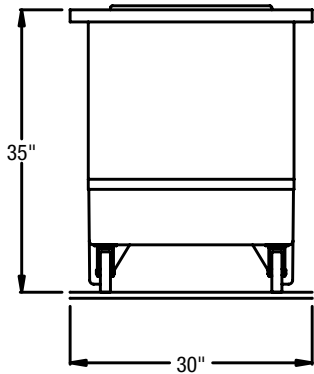

12 "PS" Model

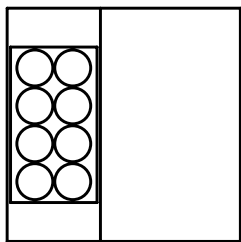

8 Model

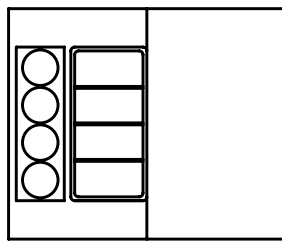

8 "PS" Model

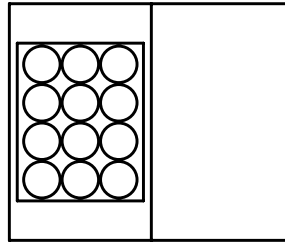

12 Model

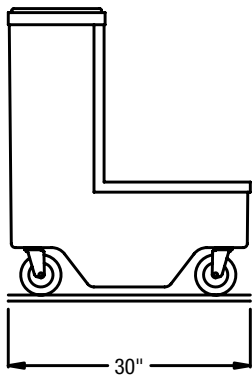

Standard 8 Model

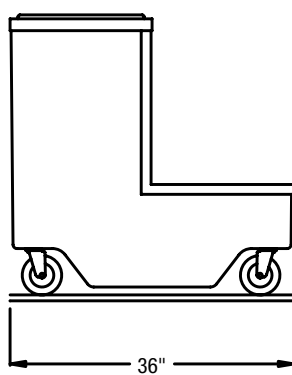

Standard 12 Model,
& 8 "PS" Model

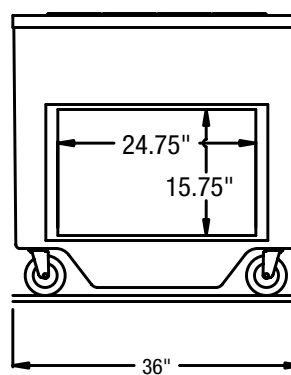

12 "PS" Model

MODEL	L	D	H	Ship Wt.
SW-8	30"	30"	35"	135
SW-12	36"	30"	35"	135
SW-8PS	36"	30"	35"	135

SILVERWARE/BIN CONFIGURATION		
SW-8	SW-12	SW-8PS
(8) round silverware bins (provided)	(12) round silverware bins (provided)	(4) 1/6 & (4) 1/3 pans (pans provided by others)