



CUSTOM

REMOTE WORKTOP REFRIGERATOR MODEL 53360

Remote refrigerator base with 16 gauge reinforced stainless steel top, and integral backsplash with 45° return. Stainless steel doors on concealed hinges. Condensing unit not provided. Evaporator blower coil with expansion valve supplied and installed. 6" high adjustable and movable legs.

SHORT FORM SPEC: Randell 53000 series model worktop refrigerator base with remote refrigeration system. Top to be 1 piece die formed stainless steel with corrosion resistant exterior body. Includes Randell evaporator blower coil fitted to base, complete with expansion valve and refrigeration lines installed for connection at rear of unit. Base interior ends and door openings shall be high impact ABS plastic with coved corner stainless steel interior to form bottom, back and top of cabinet. Base cabinet door to have ABS liner and include press-fit magnetic gaskets for positive sealing to ABS formed door opening frame. Unit to be shipped on standard 6" adjustable legs mounted to full length channel frame assembly allowing movement of legs to avoid floor obstacles.

STANDARD FEATURES:

- Available under one piece top with other modular equipment up to 16' in length
- 6" high legs—adjustable and movable
- Foamed in place "CFC free" urethane insulation
- Refrigeration system utilizes expansion valve and mechanical control for field adjustability
- 45° integral stainless backsplash is standard, 90° stainless backsplash is optional
- Filter dryer installed on liquid line

CABINET EXTERIOR: Top to be one piece of die formed 16 gauge stainless steel with 2 1/2" nosing. Backsplash to be coved cornered, with 45° return at top and overall height of 6 3/4". Ends at top fitted with recessed heavy duty steel bars for field bolting units together, producing a hairline seam. Exterior body to be corrosion resistant steel. Door opening frame to be ABS and contain magnetic strip for positive sealing of gaskets. Work surface to be at 36" work height. Legs to be 6" high stainless steel with adjustable bullet foot. Legs mounted to full length channel frame assembly which is integrally welded to bottom of body assembly. Legs can be moved left to right to avoid floor obstacles during installation.

CABINET INTERIOR: Base interior to be ABS thermoplastic at ends only. Stainless steel interior liner to be coved cornered to form bottom, back and top. One baked enamel finished shelf provided behind each door. Unit insulation to be CFC free foamed in place urethane.

DOORS: Door fronts to be 22 gauge stainless steel with 16 gauge stainless steel handles, magnetic gaskets, ABS door liner and foamed in place insulation. Hinges are concealed, all stainless steel with bronze pivot pin in nylon bushing.

REFRIGERATION: Refrigerant to be specified by customer (Specification based on R-448a refrigerant). Interior fitted with Randell evaporator blower coil for cooling base. Expansion valve and refrigeration lines provided and installed for connection at unit rear. Blower coil fitted with expansion valve for fast recovery. Condensing unit not provided. Unit totally prewired to junction box for 115V operation.

ORIGIN OF MANUFACTURE:

Designed, tested and manufactured in the United States (MI, MS).



PROJECT NAME:	
LOCATION:	
ITEM NO:	
QTY:	
MODEL NO:	
AIA NO:	
SIS NO:	
CSI SECTION:	11400



53360 shown with extended mechanical housing and finished end

OPTIONS/ACCESSORIES:

- Stainless Steel Ends
- Stainless Steel Back
- Flat Top with no backsplash
- Double Tier Drawers
- Tray Rack



DOOR OPENING SIZE - INTERIOR DEPTH

Door Width	Clearance (Lt to Rt)	Clearance (Tp to Btm)	Interior depth behind door
27"	22.25"	20.25"	26"

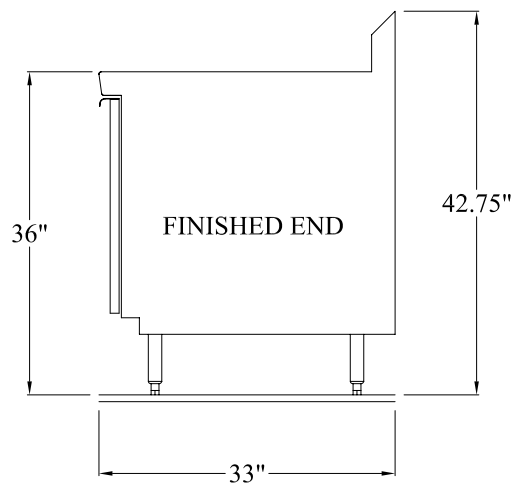
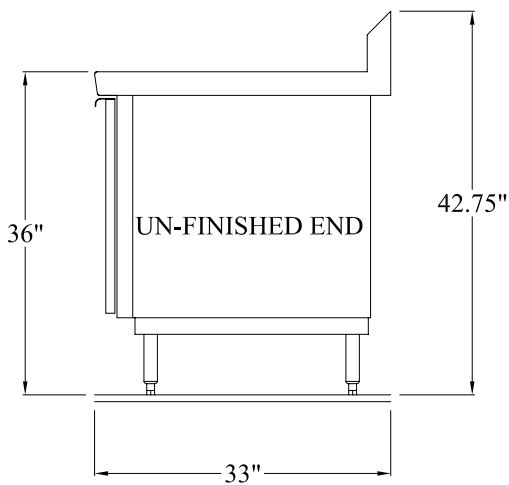
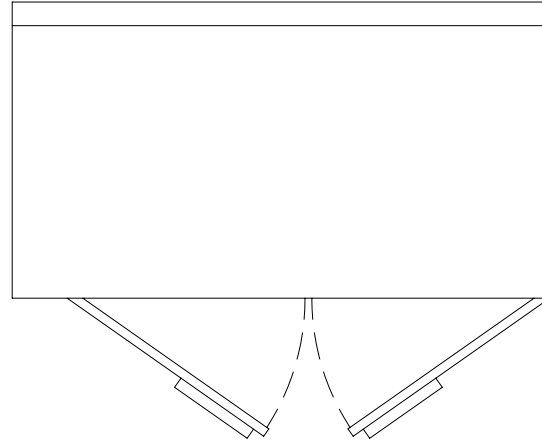
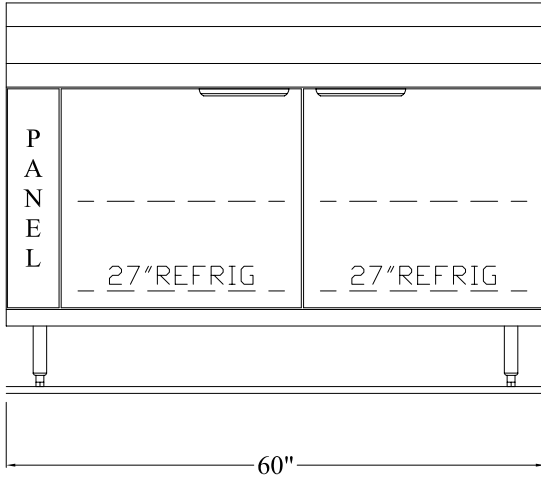

Model	L	D	H	# Doors	Storage Cu. Ft.	Volt	Amps	BTU Load	BTU Evap	Ship Wt.
53360	60"	33"	42.75"	(2)27" + 6" mech. hsg.	14.97	115/60/1	5	1045	120	485

* BTU loads shown are based on 100°F ambient with 30% added for usage and product loading. Final system selection should consider usage requirements and combined loads.