



# WATER TREATMENT SYSTEMS

## WATER TREATMENT DUAL-CARTRIDGE MODEL QTI1+CR

The QTI1+CR is a dual-cartridge water treatment system with two Qwik-Twist cartridges, which reduce sediment over 0.5 microns, reduce chlorine up to 15,000 gallons and reduce chloramine up to 6,000 gallons, when operated at a flow rate of 0.5 gpm. The system includes IsoNet®, patented scale-inhibiting technology, which minimizes the precipitation and accumulation of scale, and provides a protective barrier to help guard against corrosion.

Certifications:

PROJECT NAME:	
LOCATION:	
ITEM NO:	
QTY:	
MODEL NO:	
AIA NO:	
SIS NO:	
CSI SECTION:	11400



**APPLICATION:** STEAM & COMBI OVENS - For the reduction of chloramines, chlorine and sediment, in addition to scale and corrosion inhibition.

**INSTALLATION:**

- Feed-water connection to system should be COLD only
- Do not exceed system specifications for temperature and pressure
- Allow 3" clearance below system for filter cartridge removal and cartridge replacement
- To be used for treated water connection only
- Detailed installation, operation & maintenance manual is included with each system
- No activation procedure or flushing is required for system to perform as specified

**BENEFITS:**

- Reduces maintenance frequency and cost, and extends equipment life
- Gradient-density depth filtration reduces dirt, rust, and other debris as small as 0.5 microns to assure clean, clear water for steam generation
- IsoNet®, patented scale-inhibiting technology, helps protect equipment against scale and corrosion for the rated capacity of the system
- CTOS-QCR Catalytic Carbon provides added protection against chloramines when present in water supplies
- CTO-Q10 activated carbon filtration protects equipment against corrosive chlorine
- Sturdy, powder-coated mounting bracket and full-flow inlet shut-off valve simplify installation
- Built-in pressure gauge allows visual monitoring to interpret when filters need to be changed
- Inlet shut-off valve makes filter replacement quick and simple
- Utilizes 'Qwik-Twist' cartridges that make changing filters quick, easy and sanitary

**ADDITIONAL RESOURCES:**

- [Request A Quote](#)
- [Sales Tools](#)
- [Find A Rep](#)

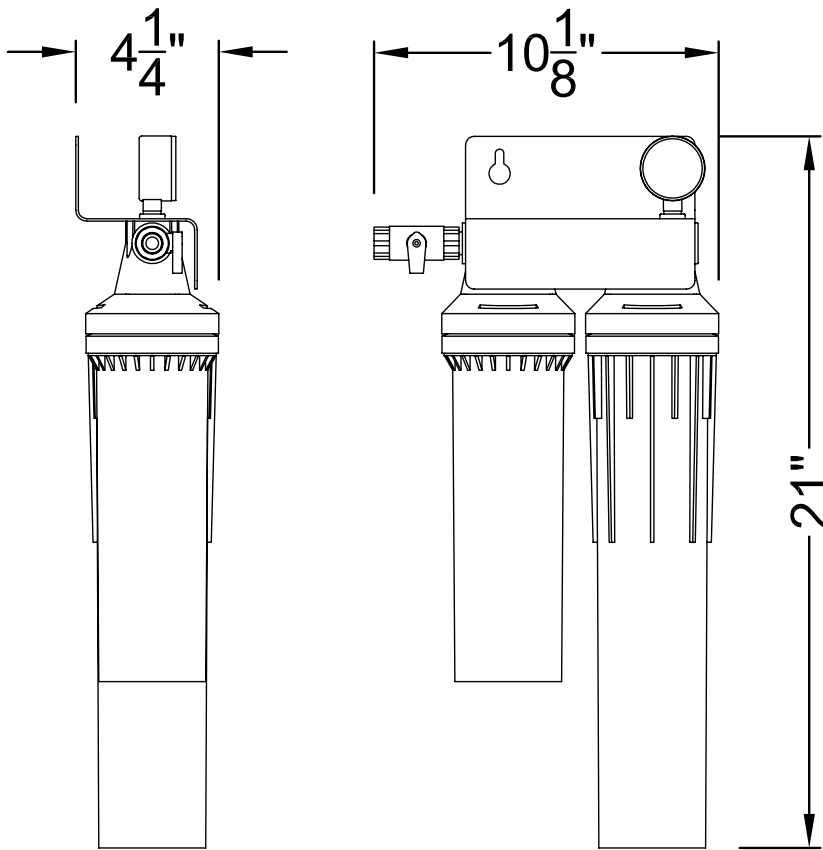

### Specifications

System	
Dimensions Height x Width X Depth, inches	21"Hx10.1"Wx4.3"D
Connection - Inlet & Outlet	3/8" NPT female
Operating Pressure Range	10-125 psi (0.7 -8.6 bar)
Inlet Water Temperature Range	35 <sup>o</sup> -100 <sup>o</sup> F (2 <sup>o</sup> -38 <sup>o</sup> C)
Shipping Weight	12 lbs.
Performance	
Chloramine Reduction Capacity	6,000 gals (22,700 liters)
Chlorine Reduction Capacity	15,000 gals (56,800 liters)
Service Flow Rate (Chloramine Reduction)	0.5 gpm (1.89 lpm)
Sediment Reduction	.5 micron (nominal)
Scale & Corrosion Inhibitor	IsoNet (70 grams)

### Replacement Media

Model	Part Number	Qty
CTO-Q10	300-05828	1
CTOS-QCR	300-05832	1

It is recommended that filters be changed every six months, when capacity is reached or when effluent pressure or flow becomes inadequate.

This product is for commercial use only and must be installed and maintained according to manufacturers' guidelines.

Do not use on water that is microbiologically unsafe or of unknown quality without adequate disinfection before or after the system .