



COOKER/MIXERS

FLOOR MOUNTED TWIN SHAFT AGITATOR DIRECT STEAM MODEL DL

Cooker Mixer Kettle shall be a Groen Model DL-40, 60, 80, TA/3 (Specify 40-, 60- or 80- gallon) stainless steel 2/3 steam jacketed unit operating from a direct steam source and complete with console-mounted tilt-out twin shaft scraper mixer.

AVAILABLE MODELS:

- DL-40 TA/3 (40 GALLON)
- DL-60 TA/3 (60 GALLON)
- DL-80 TA/3 (80 GALLON)

CONSTRUCTION: Kettle interior shall be 316 stainless steel, solid one-piece welded construction. Kettle jacket shall be 304 stainless steel solid one piece construction. Unit shall be provided with a heavy-duty reinforced rim with a heavy-duty butterfly-shaped pouring lip for maximum sanitation and durability. Unit includes 10-gallon etch markings, double pantry faucet and steam regulating system. Kettle to be tilting type with a positive locking worm and gear tilt mechanism enclosed in a polished, drip-proof stainless steel housing. Kettle mounted on a polished, stainless steel tri-leg stand with stainless steel floor flanges.

AGITATOR ASSEMBLY: Enclosed power transfer case to be cast aluminum with a 3-to-1 gear ratio. Gear motor to be completely enclosed type, cast iron housing, right angle shaft down, helical bevel gearing, variable speed motor driven through a variable electronic speed control. See table on back for minimum and maximum agitator speeds. Main agitator to be anchor-type, shaped to the contour of the kettle and provided with removable nylon finger scrapers. The secondary counter rotating agitator to be centrally located between the center shaft and the outside arms of the main agitator. Both agitators are attached with bayonet connections for easy, quick removal for cleaning or when kettle is to be used as a without the mixing mechanism. Both agitators are 304 stainless steel and either can be used alone. Agitator assembly and motor drive can be manually tilted out to the back of the kettle.

FINISH: Kettle interior shall be polished to a 180 emery grit finish. Kettle exterior shall be finished to a bright semi-deluxe buff finish to ensure maximum ease in cleaning and maintaining brilliant appearance.

ASME CODE: Unit shall be ASME shop-inspected, stamped and registered with the National Board for operation up to a maximum working pressure of 50 PSIG.

SANITATION: Unit shall be designed and constructed to be NSF listed, meeting NSF requirements.

DRAWOFF: Bottom outlet to be 2" flush mounted, sanitary, quick opening ball valve.

STEAM PRESSURE: Kettle shall operate dependably at steam pressure of 50 PSIG or below (to a minimum of 5 PSIG). Higher working pressure available. The steam supply shall be injected directly into the jacket through the trunnion and the condensate shall be removed through a tube contained in the jacket and connected to the opposite trunnion. No exposed steam piping or obstructions shall be on the kettle body.

CONTROLS: Agitator to be electronic, variable speed-control type, capable of operating at any RPM between maximum and minimum settings.

INSTALLATION REQUIREMENTS: 3/4" NPT steam inlet and condensate connection are provided. A remote steam source is required. A steam trap assembly with check valve and globe valve is provided as standard. Unit requires agitator power connection, specify 208 Volt (1 or 3-phase is standard). Other voltages are available.

ORIGIN OF MANUFACTURE: Designed and manufactured in the United States.

PROJECT NAME:

LOCATION:

ITEM NO:

QTY:

MODEL NO:

AIA NO:

SIS NO:

Stainless Steel 2/3 Steam Jacketed Cooker/Mixer, Floor Mounted, Tilting, Direct Steam, 40, 60 or 80-Gallon Capacities With Twin Shaft Agitator.



OPTIONS/ACCESSORIES:

- 240, 480 Volt Power Supply (For agitator motor)
- Kettle Brush Kit
- Pan Carrier
- Wall Mount With In Wall Carrier
- Gallon Master
- Basket Insert
- Cold Water Cooling
- Working Pressure (higher or lower than 50 PSIG)
- Lip strainers
- Contour measuring strips



P/N 141239 REV B

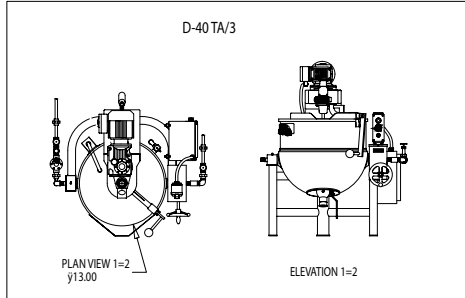

NOTES:

(DIM) ARE IN MM.

STEAM PIPING SHOWN ON PRINT ARE FOR REFERENCE ONLY. UNIT WILL BE SHIPPED WITHOUT PIPING INSTALLED.

SERVICE CONNECTIONS:

- 1: ELECTRICAL POWER CONNECTION, AGITAIOR 1-3/4" DIAMETER HOLE
- 2: AGITATOR MOTOR SPEED SWITCH.
3. STEAM INLET CONNECTION.
4. STEAM OUTLET CONNECTION.
5. COLD WATER & HOT WATER SUPPLY

TABLE OF DIMENSIONS						
MODEL	D-40 TA/3		D-60 TA/3		D-80 TA/3	
CAPACITY	40 GAL.		60 GAL.		80 GAL.	
DIM.	INCH	MM	INCH	MM	INCH	MM
A	26	660	30	762	34	864
B	43.5	1105	47.5	1207	51.5	1308
C	42	1067	44	1118	46	1168
D	7-1/2	191	7	178	4-1/2	114
E	4	102	4	102	4	102
F	10-1/2	267	11-1/2	292	10	254
G	22	559	25	635	27	686
H	36	914	40	1016	40-1/2	1029
J	54	1372	59	1500	59	1500
K	71	1803	80	2032	81	2057
L	23-1/4	591	25-1/4	641	24-3/4	629
M	22-3/8	568	24-3/4	629	26-1/8	664
N	19-5/8	498	20-5/8	524	22-7/8	581
P	30-3/4	781	34-3/4	883	38-1/4	972
Q	15-3/8	391	17-3/8	441	19-1/8	486
R	19-1/4	489	23-1/4	591	23-1/8	587
S	16	406	18	457	20	508
T	24	610	27	686	29	737
U	38-3/4	988	42-3/4	1086	43-1/4	1099
APPROX.WEIGHT	615		670		740	

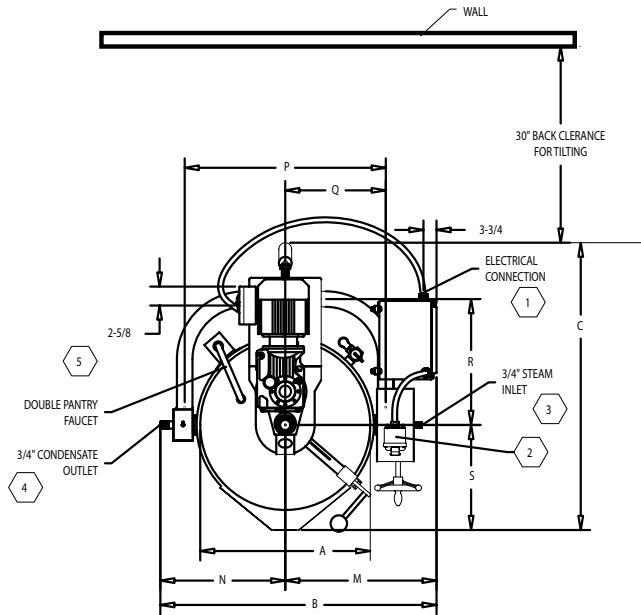

	AGITATOR MOTOR DATA SPECIFICATIONS			ELEC. LOAD RATING		
	H.P.	RPM MAIN	RPM SECONDARY	208V 3PH	240V 3PH	480V 3PH
40 GAL	MAXIMUM	1-1/2	54	5 A	4.55 A	2.28 A
	MINIMUM	3/4	27	6.3 A	5.7 A	2.83 A
60 GAL	MAXIMUM	2	46	6.8 A	6 A	3 A
	MINIMUM	1	23	4.7 A	4 A	2 A
80 GAL	MAXIMUM	2	46	6.8 A	6 A	3 A
	MINIMUM	1	23	4.7 A	4 A	2 A

