



COOKER/MIXERS

INCLINED AGITATOR KETTLE ELECTRIC MODELS DEE/4T

Cooker/Mixer shall be a Groen Model DEE/4T-40 or 60 (C,A), INA/2 (specify 40- or 60-gallon) stainless steel, self-contained, 2/3 steam jacketed unit operating from an electric heated steam source contained within unit and complete with console mounted tilt out inclined agitator mixer.



PROJECT NAME:	
LOCATION:	
ITEM NO:	
QTY:	
MODEL NO:	
AIA NO:	
SIS NO:	
CSI SECTION:	11400

AVAILABLE MODELS:

CLASSIC CONTROLS:

- DEE/4T-40C INA/2 (40 GALLON)
- DEE/4T-60C INA/2 (60 GALLON)

ADVANCED CONTROLS:

- DEE/4T-40A INA/2 (40 GALLON)
- DEE/4T-60A INA/2 (60 GALLON)

CONSTRUCTION: Kettle interior shall be of 316 stainless steel, solid one-piece welded construction. The control console and kettle exterior shall be 304 stainless steel. The kettle body shall be mounted on a heavy duty stainless steel, combination kettle support tilt trunnion which is supported by the polished stainless steel enclosed base. The kettle shall be furnished with heavy duty reinforced rim with a butterfly shaped pouring lip for maximum sanitation and ease of pouring. The base shall be provided with stainless steel tubular legs with adjustable flanged feet. The enclosed support base shall contain a self-locking worm and gear tilt mechanism, contactor, etc., and shall be of sanitary drip-proof construction with interior readily accessible for installation or maintenance. Unit includes 2" TDO and 10-gallon etch markings and double pantry faucet.

FINISH: Interior of kettle shall be polished to a 180 emery grit finish. Exterior of kettle shall be finished to a bright semi-deluxe finish, ensuring maximum ease in cleaning and maintaining brilliant appearance.

AGITATOR ASSEMBLY: Agitator assembly to be designed to thoroughly fold and blend product with gentle lifting action provided by agitator entering kettle body at an angle. Inclined agitator to be stainless steel tubular frame, complete with shovel-type scrapers. Agitator to be readily removable for ease of cleaning and maximum sanitation. Unit driven by a gear motor through an electronic variable speed control. Motor is completely enclosed with a cast iron housing, helical bevel gearing and right angle shaft down. Motor drive is mounted on a stainless steel channel that manually hinges out to the right side of kettle. Unit to be equipped with a spring assist for agitator tilt out. A positive quick-action lock and latch mechanism to be provided to secure the agitator when it is in the kettle.

ASME CODE & UL LISTING: Unit shall be ASME shop inspected, stamped and registered with the National Board for operation up to a maximum working pressure of 50 PSI. Kettle is UL listed.

SANITATION: Unit shall be designed and constructed to meet NSF requirements, and be NSF listed.

SELF CONTAINED STEAM SOURCE: Kettle shall have an electrically heated self-contained steam source to provide kettle temperatures of 150°F to approximately 295°F. Unit shall be factory charged with water and rust inhibitors to ensure long life and minimum maintenance.

CONTROLS: Controls to be located in right-side water resistant (IPX6 rated) trunnion enclosure:
Classic -C Models include: Power ON-OFF switch with indicator light, temperature control knob with 1 to 10 increments, HEAT(ing) indicator light and LOW WATER warning light. **Advanced -A Models** include: Power ON-OFF switch with indicator light, temperature & time set knob, HEAT(ing) indicator light, LED display of set heat level or cook time, buttons for reset of Low Temp and High Temp presets, MANUAL mode button for knob-setting of heat level, and TIMER set button with indicator light. The agitator has on-off and variable speed control switch.

SAFETY FEATURES: Kettle shall have safety cut-off (cuts off heat when tilted to an angle above 10 degrees), pressure relief valve, high limit pressure switch and low water cut off, 24V control system, and agitator safety tilt cut off.

INSTALLATION REQUIREMENTS: Unit requires two electrical connections, standard 208 volt, 3-phase for kettle; Standard 208 volt, 3-phase for agitator motor.

OPTIONS/ACCESSORIES:

- Disk strainers (not to be used with agitator)
- 240, 480 Volt power supply (specify for kettle or motor)

- Kettle brush kit
- Pan carrier
- Gallon master
- Basket insert
- Lip strainers
- Contour measuring strips

ADDITIONAL RESOURCES:

- [Request A Quote](#)
- [Sales Tools](#)
- [Find A Rep](#)

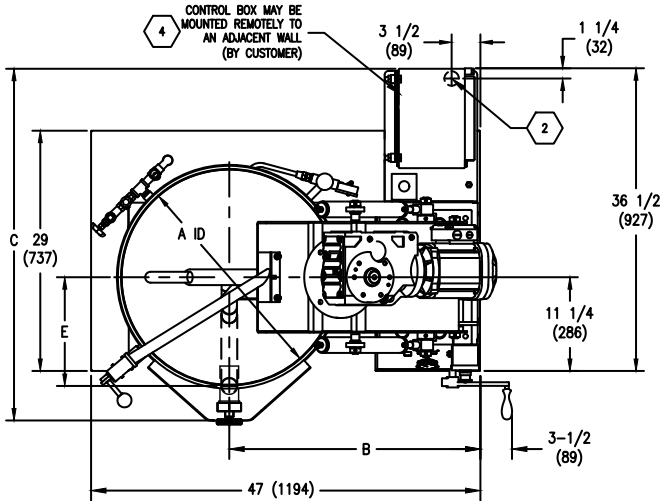

VOLTAGE	PHASE	LOAD	POWER
208 V	1 PH	101 A	21 KW
	3 PH	59 A	
240 V	1 PH	105 A	24 KW
	3 PH	61 A	
480 V	3 PH	29 A	

MODEL	40 GAL.	60 GAL.	150 L	230 L
DIM.	INCH	MM	INCH	MM
A	26	660	30	762
B	30 1/4	768	32 1/4	819
C	42 3/4	1086	44 1/4	1124
D	46 7/8	1191	50 1/4	1276
E	13 1/8	333	13 1/8	333
F	32 5/8	829	36 1/2	927
G	11 5/8	295	15 1/2	394
H	55	1397	55	1397
J	57 1/2	1460	61 1/2	1562
K	78-1/8	1984	81-3/8	2067
L	13-7/8	352	12-7/8	327
M	11-1/4	286	9 3/4	248

NOTES:

- ELECTRICAL POWER CONNECTIONS, KETTLE 1-3/4" DIAMETER HOLE (BACK SIDE).
- ELECTRICAL POWER CONNECTION, AGITATOR 1-3/4" DIAMETER HOLE (BOTTOM SIDE).
- AGITATOR MOTOR SPEED SELECTOR SWITCH.
- CONTROL BOX MAY BE REMOTELY MOUNTED (BY CUSTOMER) IF DESIRED.

	AGITATOR MOTOR SPEED		ELEC. LOAD RATING			
	RPM	MAIN	H.P.	208V 3PH	240V 3PH	480V 3PH
40 GAL	MAXIMUM	36	1-1/2	5 A	4.55 A	2.28 A
	MINIMUM	8	3/4	6.3 A	5.7 A	2.83 A
60 GAL	MAXIMUM	36	2	6.8 A	6 A	3 A
	MINIMUM	8	1	4.7 A	4 A	2 A

