



CUSTOM

TOP EXTENSION MODEL 18000 & 19000

Drawer base utility stand with 16 gauge reinforced stainless top, and integral backsplash with 45° return. Self-closing dry storage drawers on 16 gauge tracks with 1 5/8" stainless bearings and removable plastic pans. 6" high adjustable and movable legs.

PROJECT NAME:

LOCATION:

ITEM NO:

QTY:

MODEL NO:

AIA NO:

SIS NO:

CSI SECTION: 11400

18000 STAINLESS STEEL TOP EXTENSION OPEN TO FLOOR

Stainless steel top extension open to the floor with stainless steel finished interior. Ship weight of 60 lbs/ft.

- Up to 18"
- 24"
- 36"
- 48"
- 60"
- 72"
- 84"
- 96"

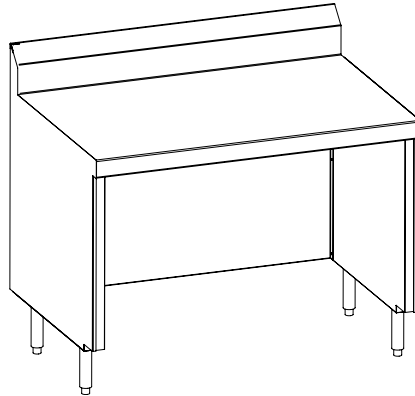
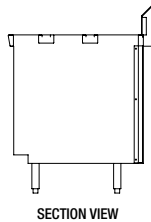

19000 STAINLESS STEEL TOP EXTENSION WITH REMOVABLE FRONT PANEL

Removable stainless steel front panel includes reinforced top and galvanized sides. Top depth to match adjacent equipment (specify as required). Ship weight of 60 lbs/ft.

- Up to 18"
- 24"
- 36"
- 48"
- 60"
- 72"
- 84"
- 96"

