



# ROLL-IN

## DOUBLE DOOR FREEZER MODEL RS2F-67-2RI

The Model RS2F-67-2RI represents Randell's *Specification Series* roll-ins in a dual section freezer. This model is designed to provide maximum menu flexibility in a small vertical footprint. The single compressor system is designed to meet the latest DOE energy standards and is balanced with the highest quality components and controls to provide exceptional performance for the operator.

### STANDARD FEATURES:

- Energy efficient single compressor system
- Digital controls
- Automatic adaptive defrost system
- Efficient hot gas condensate evaporator
- LED interior lighting
- Integrated door alarm
- Door locks
- 9' cord and plug
- Heavy duty stainless steel ramps
- Thermostatic expansion valve

### CABINET CONSTRUCTION:

- Exterior Front: Stainless Steel
- Exterior Sides: Stainless Steel
- Exterior Body: Galvanized Steel
- Interior Sides: Stainless Steel
- Interior Floor: Stainless Steel
- Insulation is foamed in place high density polyurethane

### DOORS:

- Exterior: Stainless Steel
- Interior: Stainless Steel

Doors are self-closing with heavy duty cam lift hinges. The door stays open after 90-degrees for easy loading. Cabinet is provided with door pressure relief device to assist in easy opening of the doors. Interior is illuminated with door activated, energy efficient LED lighting.

**REFRIGERATION SYSTEM:** Self-contained refrigeration system using R-290 is balanced to regulate top mounted evaporator coil providing superior air circulation to the storage compartment. Condensate is evaporated by a rear mounted hot gas system that has protective coating on hot gas loop for extended life. Freezer is designed to operate between -10°F and 0°F. Standard settings are easily managed by simple up/down arrows. The controller includes an audible alarm which produces three low-volume beeps after the door is open for thirty seconds.

**ELECTRICAL:** Unit comes from the factory prewired with a 9ft. cord and plug and ready for plugging into a dedicated 115/60/1 phase, 15-amp outlet.

PROJECT NAME:

LOCATION:

ITEM NO:

QTY:

MODEL NO:

AIA NO:

SIS NO:

CSI SECTION: 11400



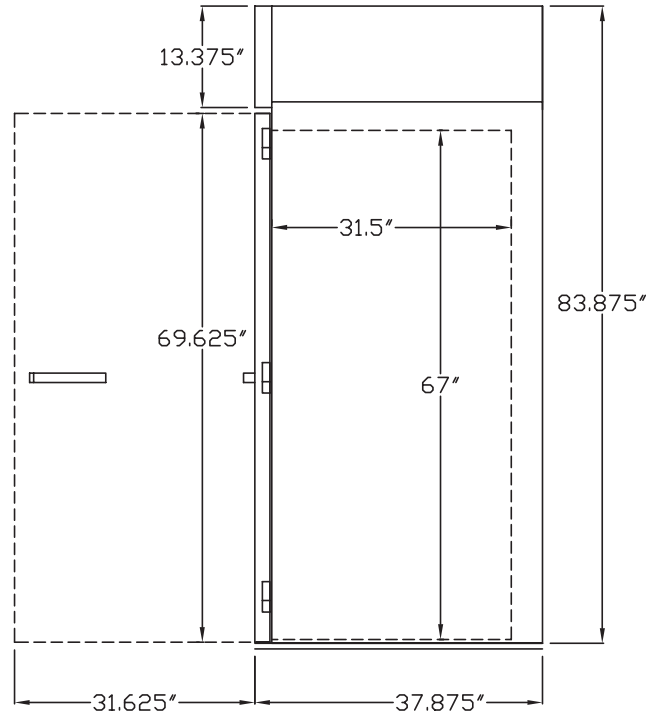
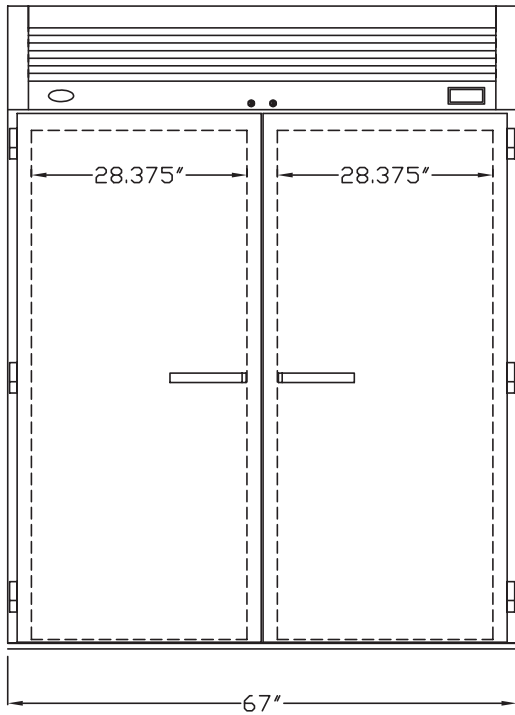
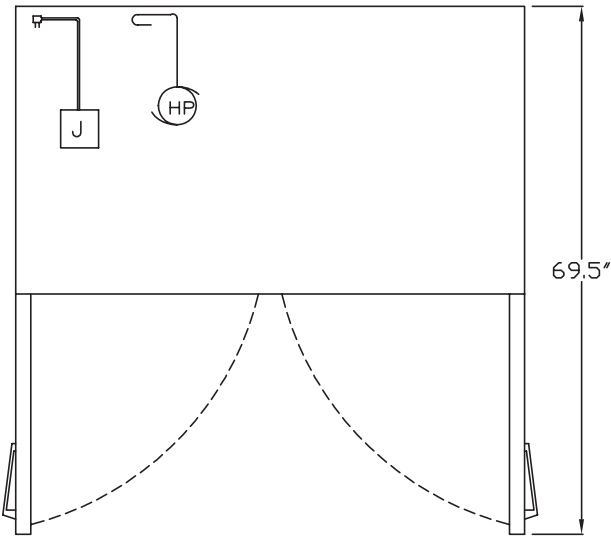

Model	Hinged	L	D	H	Doors	Storage Cu. Ft.	Racks (Not Provided)	HP	Power	Amps	NEMA	Ship Wt.
RS2F-67-2RI	Left/Right	67"	37.875"	83.875"	2	81	(2) 27"x29"x66"	1	115/60/1	5.5	5-15P	590