



CAPKOLD® COOK-CHILL SYSTEMS

NON TILT-OUT AGITATOR KETTLE MODEL AH/INA2

CapKold® Kettle shall be a Groen Model AH/INA (specify 80 or 100 gallons) stainless steel, self-contained, steam jacketed agitating kettle operating from gas heated steam source contained within unit.

PROJECT NAME:

LOCATION:

ITEM NO:

QTY:

MODEL NO:

AIA NO:

SIS NO:

AVAILABLE MODELS:

- AH/INA-80 (80 GALLON)
- AH/INA-100 (100 GALLON)

CONSTRUCTION: Kettle interior shall be of type 316 stainless steel, with solid one-piece construction. All exposed surfaces shall be stainless steel. All controls shall be contained within front control enclosure. Kettle body is sheathed in stainless steel and insulated with fiber bat insulation. Unit provided with three adjustable legs for leveling. Faucet mounting bracket is standard.

FINISH: Interior of kettle shall be polished to a 180 emery grit finish. Exterior shall be finished to a uniform #3 satin finish ensuring maximum ease in cleaning and maintaining appearance.

ASME CODE: Unit shall be ASME shop inspected, stamped and registered with the National Board for operation up to a maximum working pressure of 30 PSI.

SANITATION: Unit shall be designed and constructed to meet NSF requirements and be NSF listed.

DRAWOFF VALVE: Unit shall have a 2" sanitary tangent drawoff which is made of 316 stainless steel. Valve has durable insulated handle, rubber compression sealing disk and is easy to disassemble without tools. The drain outlet shall be equipped with a removable 1/4" perforated stainless steel strainer.

AGITATOR DESIGN:

- Inclined, easily removable agitator and breaker bar, with removable nylon edge scraping blades which scrape entire heat exchange surface
- Variable speed gear motor drive with 7-36 rpm operating range
- Heavy duty T.E.F.C. motor

CONTROLS: All controls shall be contained in a stainless steel enclosure. Controls include a regulating thermostat, pressure gauge, power-ON switch, power-ON indicator light, heat indicator light, low water indicator light, water sight gauge, pressure safety valve, pressure limit control, low water cut off, a gas regulator valve and electronic ignition module; with all operating controls front mounted.

PERFORMANCE FEATURES: Unit shall be thermostatically controlled to automatically shut off when desired temperature is reached and turn on when product temperature drops below desired setting. Electronic ignition to standing pilot is standard. Outer sheathing and fiber insulation retain heat and keep kettle exterior cool to the touch.

SELF-CONTAINED STEAM SOURCE:

Kettle shall have a gas-heated, 145,000 BTU, self-contained steam source to provide kettle temperatures of 150 to 270°F. Unit shall be factory charged with water and rust inhibitor to ensure long life and minimum maintenance.

INSTALLATION: Unit requires 1/2" NPT gas line connection and 115 volt electric supply to operate controls. No remote steam source required.

ORIGIN OF MANUFACTURE: Designed and manufactured in the United States.



OPTIONS/ACCESSORIES:

- Basket inserts (TRI-BC)
- Water fill faucets
- Other supply voltages
- Kettle brush kit
- Contour measuring strip
- Gallon etch marks
- Tri clover flange fitting
- Ball valve

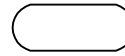
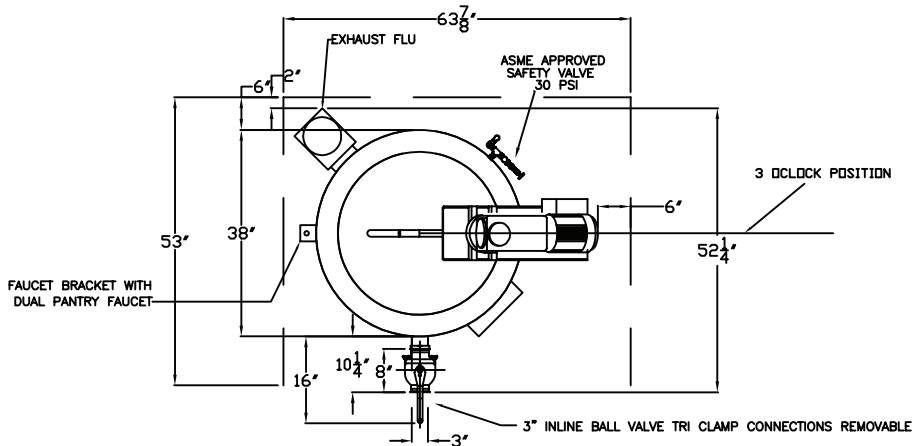

1
Groen
AH/1E-100 INA/2
Kettle, Steam Jacketed, Gas Stationary

SERVICE CONNECTIONS AND NOTES:

1. GAS KETTLE: NAT OR LP - VERIFY
1/2" GAS CONNECTION
NAT GAS 4.5" TO 14" W.C. MAX - 145,000 BTU/HR
PROPANE 11" TO 14" W.C. MAX - 145,000 BTU/HR
2. ELECTRICAL REQUIREMENTS - 2 CIRCUITS REQUIRED - VERIFY 3 PHASE VOLTAGE
ELECTRICAL MOTOR: 208V 6 AMPS - 480V 2.6 AMPS , 3 PH, 60 HZ,
CONTROLS - 115V/1/60 2 AMPS - SEPARATE REQUIRED CIRCUIT
3. WATER CONNECTION: 1/2 NPT.
4. MINIMUM CLEARANCE REQUIRED.

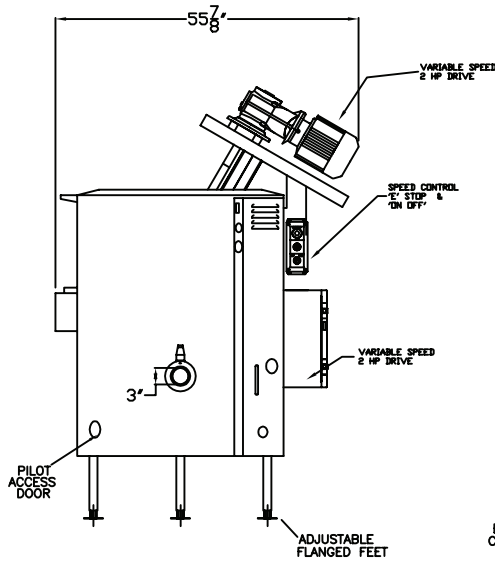

FRONT VIEW

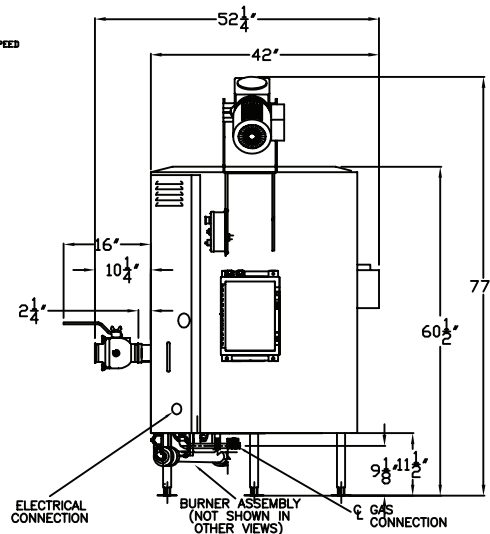

RIGHT SIDE VIEW