



ROLL-IN

SINGLE DOOR REFRIGERATOR MODEL RS1R-35-1RI/L

The Model RS1R-35-1RI/L represents Randell's *Specification Series* roll-ins in a single section refrigerator. This model is designed to provide maximum menu flexibility in a small vertical footprint. The single compressor system is designed to meet the latest DOE energy standards and is balanced with the highest quality components and controls to provide exceptional performance for the operator.

AVAILABLE MODELS:

- RS1R-35-1RI (Right Hinged)
- RS1R-35-1RIL (Left Hinged)

STANDARD FEATURES:

- Energy efficient single compressor system
- Digital controls
- Automatic adaptive defrost system
- Efficient hot gas condensate evaporator
- LED interior lighting
- Integrated door alarm
- Door lock
- 9' cord and plug
- Heavy duty stainless steel ramp
- Thermostatic expansion valve

CABINET CONSTRUCTION:

- Exterior Front: Stainless Steel
- Exterior Sides: Stainless Steel
- Exterior Body: Galvanized Steel
- Interior Sides: Stainless Steel
- Interior Floor: Stainless Steel
- Insulation is foamed in place high density polyurethane

DOORS:

- Exterior: Stainless Steel
- Interior: Stainless Steel

Doors are self-closing with cam lift hinges. The door stays open after 90-degrees for easy loading. Cabinet is provided with door pressure relief device to assist in easy opening of the doors. Interior is illuminated with door activated, energy efficient LED lighting.

REFRIGERATION SYSTEM: Self-contained refrigeration system using R-290 is balanced to regulate top mounted evaporator coil providing superior air circulation to the storage compartment. Condensate is evaporated by a rear mounted hot gas system that has protective coating on hot gas loop for extended life. Refrigerator is designed to operate between 33°F and 38°F. Standard settings are easily managed by simple up/down arrows. The controller includes an audible alarm which produces three low-volume beeps after the door is open for thirty seconds.

ELECTRICAL: Unit comes from the factory prewired with a 9ft. cord and plug and ready for plugging into a dedicated 115/60/1 phase, 15-amp outlet.

PROJECT NAME:

LOCATION:

ITEM NO:

QTY:

MODEL NO:

AIA NO:

SIS NO:

CSI SECTION: 11400

Note: hinged right model shown





RS1R-35-1RI Right hinged:

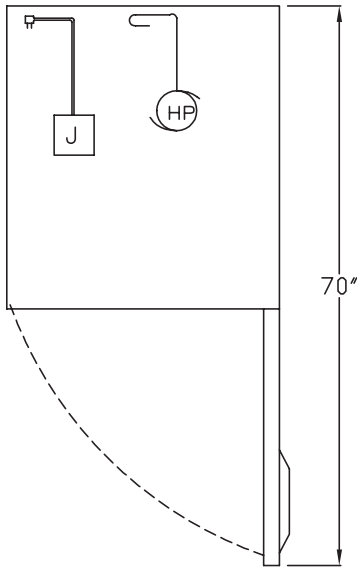

RS1R-35-1RIL Left hinged:

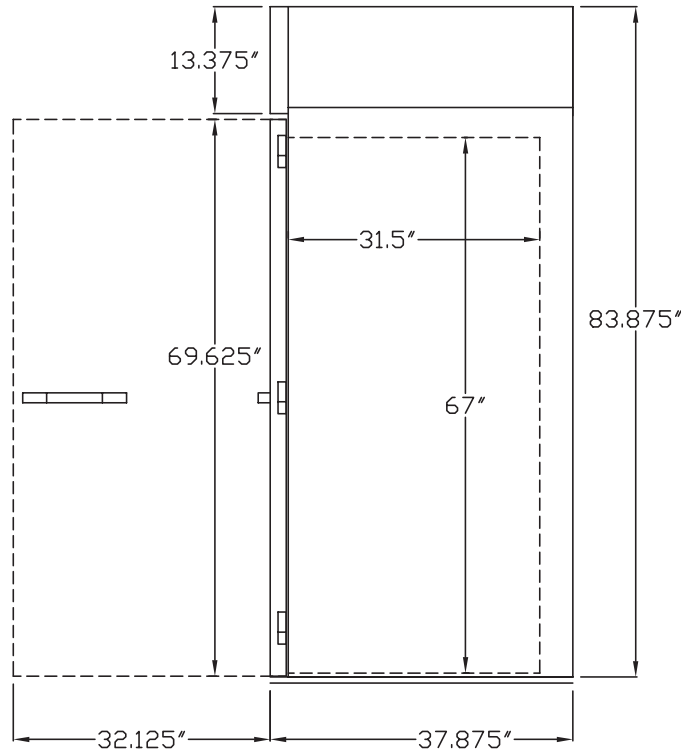
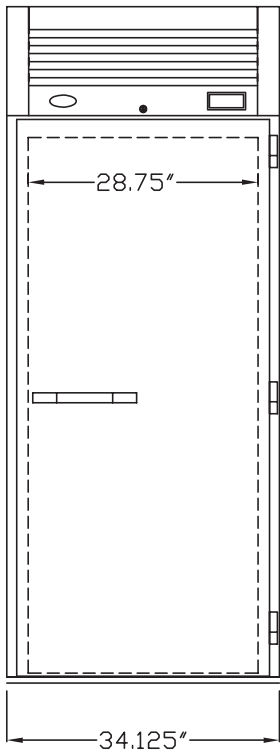
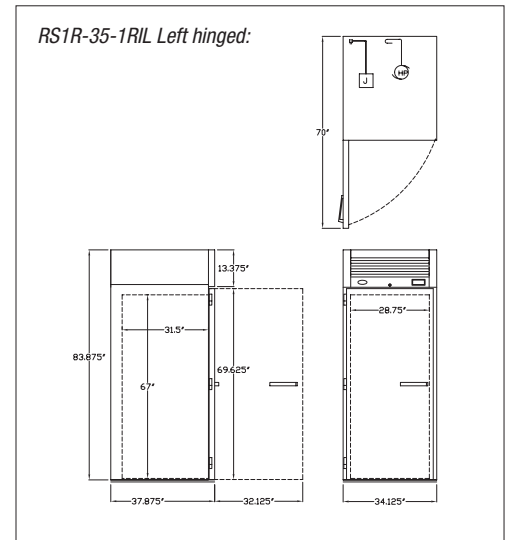

Model	Hinged	L	D	H	Doors	Storage Cu. Ft.	Racks (Not Provided)	HP	Power	Amps	NEMA	Ship Wt.
RS1R-35-1RI	Right	34.125"	37.875"	83.875"	1	40	(1) 27"x29"x66"	1/3	115/60/1	4.1	5-15P	410
RS1R-35-1RIL	Left	34.125"	37.875"	83.875"	1	40	(1) 27"x29"x66"	1/3	115/60/1	4.1	5-15P	410