



# REACH-IN

## SOLID DOOR DUAL TEMPERATURE MODEL R1DT-25-1FB

The Model R1DT-25-1FB represents Randell's *Standard Series* reach-ins in a single section dual temp refrigerator / freezer. This model is designed to provide maximum menu flexibility in a small vertical footprint. The single compressor system is designed to meet the latest DOE energy standards and is balanced with the highest quality components and controls to provide exceptional performance for the operator. Right hinged, refrigerator top, freezer bottom.

### STANDARD FEATURES:

- Energy efficient single compressor system
- Digital Controls for both the freezer and refrigerator
- Independent temperature read-outs for both freezer and refrigerator
- Freezer is equipped with rapid pull-down function (Quick-Freeze)
- Refrigerator controller has 28°F preset (Meat) feature button to hold proteins at a colder temperature
- Automatic adaptive defrost system
- Efficient hot gas condensate evaporator
- Door activated LED interior lighting
- Adjustable, heavy duty, coated wire shelves
- 9' Cord and plug
- Door lock with integral top/bottom door clasp
- 5" Casters (front two locking)
- Door pressure relief valve

### CABINET CONSTRUCTION:

- Exterior Front: Stainless Steel
- Exterior Sides: Stainless Steel
- Exterior Body: Galvanized Steel
- Interior Sides: Anodized Aluminum
- Interior Floor: Stainless Steel

Insulation is foamed in place high density polyurethane. Units provided with coated wire shelves with rear vertical turn-up to assure proper air flow. Each shelf is adjustable. Unit is provided with 5" casters (field installed) are affixed to bottom of unit.

### DOORS:

- Exterior: Stainless Steel
- Interior: Anodized Aluminum

Doors are self-closing with torsion type concealed hinges providing a clean exterior look suitable for front of the house installations. The door stays open after 90-degrees for easy loading. Cabinet is provided with door pressure relief device to assist in easy opening of the doors. Interior is illuminated with energy-efficient LED lights on individually door activated switches.

**REFRIGERATION SYSTEM:** Self-contained compressor refrigeration system balanced to regulate interior mounted evaporator coil providing superior air circulation to the storage compartment. Top-mounted compressor design provides easier access for preventative maintenance and condenser cleanings and accumulates less dirt than bottom-mount compressors. Condensate is evaporated by a rear mounted hot gas system that has protective coating on hot gas loop for extended life. Refrigerator is designed to operate between 33°F and 40°F with a preprogrammed "Meat" button that cools to 28°F to provide superior protein quality and shelf life. Freezer is designed to operate between -10°F and 0°F and has a rapid pull-down button (Quick-Freeze) that temporarily runs the unit at full capacity to provide continuous cooling. One push of either the Meat or Quick-Freeze button returns the units to preset running temperatures. Standard settings are easily managed by simple up/down arrows. The controllers also have lighted door open indicators which are followed by three low-volume beeps after the door is open for thirty seconds as well as fan-on indicators.

**ELECTRICAL:** Unit comes from the factory prewired with a 9ft. cord and plug and ready for plugging into a dedicated 115/60/1 phase, 15-amp outlet.

PROJECT NAME:

LOCATION:

ITEM NO:

QTY:

MODEL NO:

AIA NO:

SIS NO:

CSI SECTION: 11400



### OPTIONS/ACCESSORIES:

- Extra interior shelves

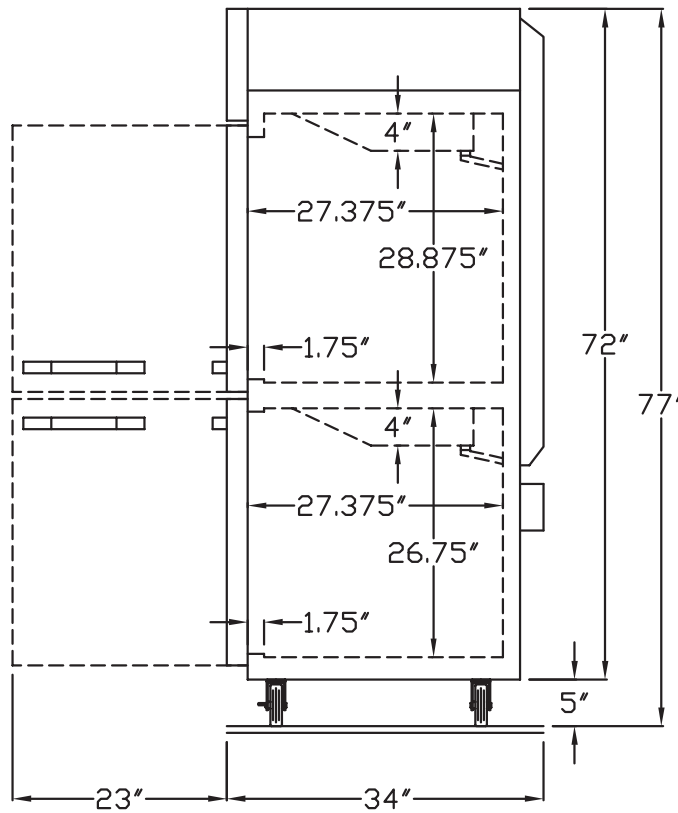
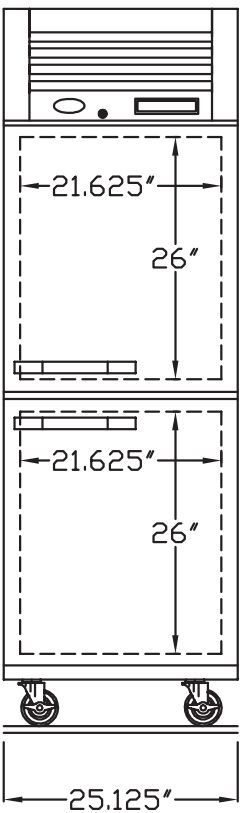
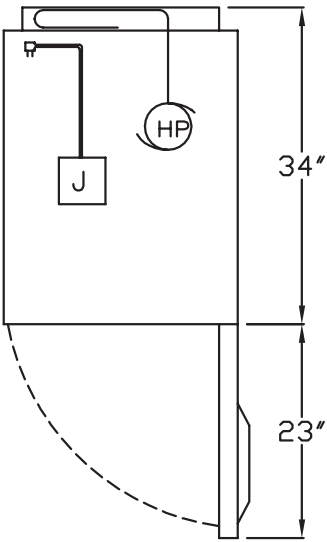

Model	Top Section	Bottom Section	Hinged	L	D	H	Doors	Cu. Ft. Top/Btm	Shelves	HP	Power	Amps	NEMA	Ship Wt.
R1DT-25-1FB	Refrigerator	Freezer	Right	25 1/8"	31 1/2"	77"	(2) 1/2	8.5(R) 7.9(F)	2	3/8	115/60/1	4.8	5-15P	220