



CONVEYORS

SLAT BELT OVERLAPPING PLASTIC MODEL CBSW

The Avtec Model CBSW is a soiled tray/dish return conveyor utilizing an overlapping style plastic slat attached to a stainless steel chain to return soiled trays from the dining room to the dish room or to move dishes or racks within the dish room. Belt is returned in self-cleaning slider pan for easy cleaning and maintenance. Turns are accomplished by use of an internal roller in each slat, which takes the strain off of the belt and relieves stretching and extends belt life. Unit is provided with automatic detergent injection wash system.

SHORT FORM SPEC: Avtec Slat Belt conveyor systems are designed to move plates, trays, racks, and bus tubs into & through the dish room allowing for ergonomic movements of staff to clean & load dish machines. Slat belt system includes ABS plastic slats that snap in place on the 3/4" stainless steel chain, driven by an expanding hub style drive system to prevent motor or system damage, along w/ automated wash system. All stainless steel construction throughout.

STANDARD FEATURES:

- Auto belt tensioner
- 1 5/8" S/S legs with 1 1/2"
- S/S cross members
- Work surface: 14 ga S/S construction, fully welded and polished
- 1/2 HP S/S drive motor (typ. for under 60' with one turn)
- 3/4 HP S/S drive motor (typ. for over 60' with one or more turns)
- S/S side flexing #60 chain
- Side flexing slats with rollers, for smooth turns, standard color black
- Self cleaning return track
- S/S drive sprocket
- Lifetime drive bearings
- Tail cover
- Slats can be easily replaced
- S/S drive housing
- S/S drive motor
- Door conveyor shut off safety switch(s)
- Removable scrap basket in drive and tail housings
- Access panel for wash housing
- 1 1/2" Drain in drive
- Anti-jam safety switch at drive opening
- Detergent pump housing
- Belt wash, with auto wash option (PIC programmed timer for optimal cleanness and performance)
- Main control panel with start/stop, wash selector, belt speed, limit switch, main disconnect
- Limit switch

SPECIFICATIONS: Provide AVTEC NSF Approved soiled tray/dish conveyor system, Model CBSW. Unit shall be integral with dish table and tray scrapping system and will be size and shape as shown in project drawings. Top and slide bed shall be constructed of 14 gauge 300 series stainless steel with #4 mill finish.

Drive housing shall be of uni-body construction, completely constructed of 300 series stainless steel. Legs shall be 1 5/8" diameter stainless steel with 1 1/2" diameter welded cross members for support. Drive motor to be stainless steel (1/2)(3/4) HP, 208/3 and shall be water resistant.

Motor is to be located in separate housing from wash tank compartment. Housing is to be provided with door safety shut-off switch. Unit is to include wash housing with strategically designed spray jets for cleaning of both sides of belt. Belt returns on self-cleaning return track system. Detergent designed to drip on belt for maximum exposure to cleaning action. Wash housing is designed with large access panels for inspection of wash chamber and comes complete with stainless steel latches to seal openings and removable scrap basket for waste.

Belt is to be overlapping style black plastic with integral rollers to minimize belt friction, riding in continuous length UHMW tracks, driven by a stainless steel sprocket mounted on stainless steel bearings and shafts utilizing slip collar in lieu of keyways. Tail section includes auto-tensioning device to keep constant equal tension on the belt.

Motor control panel to be designed with main service disconnect switch, variable speed controls and of sealed water-tight construction. Conveyor is designed to include a photo electric accumulation switch at terminal end of unit to shut down system when conveyor is full.

Certifications:



PROJECT NAME:	
LOCATION:	
ITEM NO:	
QTY:	
MODEL NO:	
AIA NO:	
SIS NO:	
CSI SECTION:	11400



Model CBSW shown

OPTIONS/ACCESSORIES:

- Hinged tail access door
- Auto (APRs) or manual (MPRs) plate rinses
- Additional start/stop box(s)
- Auto-indexing system
- Wall or post mounted rack shelf
- Wall or post mounted tubular rack shelf
- Hose reel:
 - 30' hose
 - 50' hose
- Integrated dish table per drawings
- Laminated or S/S panels at drop off
- Sight and sound barrier
- Security door
- Dual belt design for accumulator application.
- Side skirting:
 - Hinged
 - Removable

ADDITIONAL RESOURCES:

- [Request A Quote](#)
- [Product Videos](#)
- [Sales Tools](#)
- [Find A Rep](#)

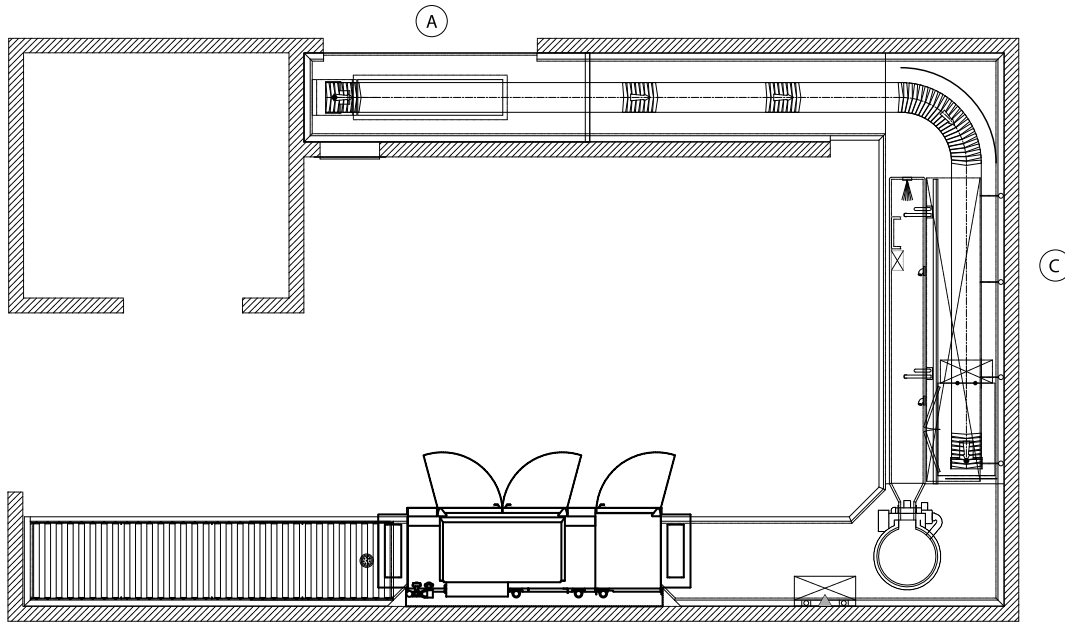

PLAN VIEW - TYPICAL DISH ROOM

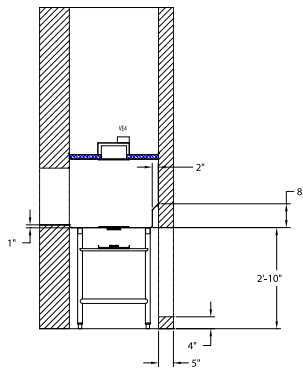

TYPICAL SECTION VIEW

A

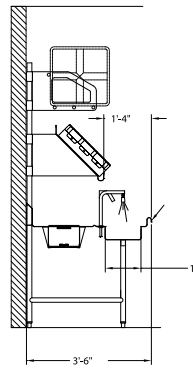

TYPICAL SECTION VIEW

C

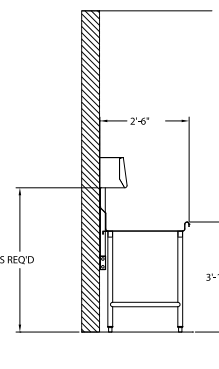

TYPICAL SECTION VIEW

D

TYPICAL SYSTEM FEATURES

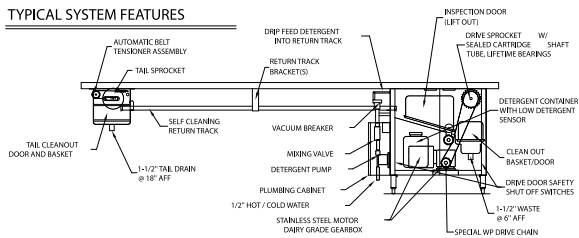

UTILITY ROUGH IN LOCATIONS
REFER TO PLAN VIEW FOR ADDITIONAL DRAIN LOCATIONS IF REQUIRED.

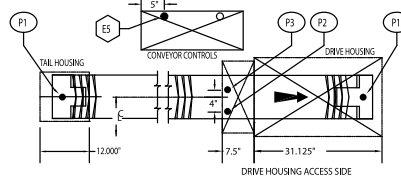

CONVEYOR CONTROLS

