



UTILITY RACEWAYS

M SERIES MODEL MWD

The M-series Raceway is a Utility Distribution System comprised of a stainless steel sheet metal housings enclosing cable bus electrical system and plumbing services that provide connections for individual appliances. Raceways with plumbing services are Listed by Underwriters Laboratories (UL) as Commercial Appliance Outlet Centers. Raceways with only electrical services are Listed by UL as Multi-outlet Assemblies. These raceways are intended primarily for use behind a cooking battery, or cooking appliance line-up. Individual Point-of-use connection plates are located near the top along the length of the raceway.

SHORT FORM SPEC: The Avtec MWD raceway is a Wall Utility Distribution System comprised of a stainless steel housing enclosing a cable bus electrical system, and plumbing services that provide connections for individual appliances. The electrical system is to include single point electrical service with all other outlets & breakers being factory wired. The plumbing system is to include single point (or looped based on capacity) plumbing service with all other manifolds, disconnects, and valves where applicable. Breakers are mounted on the connection plate that includes the outlet.

STANDARD FEATURES:

- Point-of-use branch circuit protection with receptacle or flexible liquid tight metal conduit (pigtail) mounted adjacent to branch circuit protection on 4.5x12" connection plate
- Ground fault circuit interrupter for 15 & 20 amp, 120/1, straight blade receptacles
- Cable bus
- Copper hot and cold water supply lines, if required
- Black iron gas supply line, if required
- Quarter-turn shut-off valves on all individual gas connections
- Quarter-turn shut-off valves on main supply valves
- 2" High collar at top of service tower allows ±1/2" vertical adjustment to compensate for floor and/or exhaust hood mounting irregularities

SPECIFICATIONS: Dimensions: Horizontal Chase Width: 6" [generally for plumbing services less than 2" NPT] or 8" [generally for plumbing services 2" NPT or greater], Height: 18" – 30" plus 3-6" peaked top, Length: as required. Service Towers Width: 6-12" Height: Finished Floor to Exhaust Hood or Finished Ceiling, Length: 18" Nominal to 42" Nominal. Intermediate Pedestals Width: 5-8" Height: Finished Floor to bottom of Horizontal Chase, Length: 5-8". Construction: 300-series Stainless Steel. Removable panels held in place with threaded fasteners. Electrical Data: 30 to 150 amperes. 120/208-240 volts. Single- or three-phase. Water: 150 psig & 140° F (60° C) maximum. Gas (Natural gas or LP): 1.25 psig

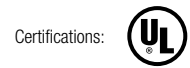

PROJECT NAME:	
LOCATION:	
ITEM NO:	
QTY:	
MODEL NO:	
AIA NO:	
SIS NO:	
CSI SECTION:	11400

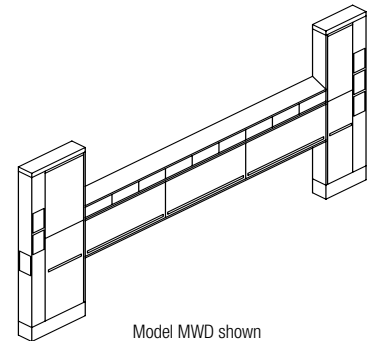

Model MWD shown

OPTIONS/ACCESSORIES:

- Main electrical service circuit breaker with shunt trip
- Quick-disconnect fittings for individual gas connections in addition to quarter-turn shut-off valves for movable appliances
- Quick-disconnect fittings for individual water connections in addition to quarter-turn shut-off valves for movable appliances
- Vent light switch in service tower
- Vent light switch with circuit breaker in service tower
- Duplex convenience outlet in service tower(s)
- Gas delay reset (GDRI)
- 120V AC fire-fuel shut-off solenoid valve(s) for gas supply. 1 1/2" And smaller located in service tower(s) (2" and larger are remotely located)
- Temperature/pressure gauge at water incoming service location

ADDITIONAL RESOURCES:

- [Request A Quote](#)
- [Sales Tools](#)
- [Find A Rep](#)

FRONT, TOP, SIDE VIEWS

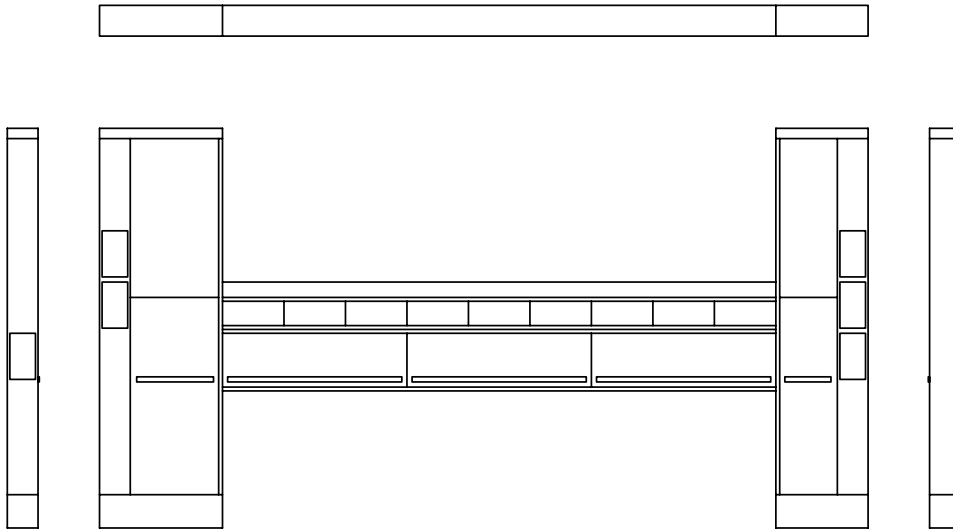

OPTIONS/ACCESSORIES CONTINUED:

- Security package (includes):
 - exposed fasteners to be tamper-resistant, pin-in-head torx-head, shipped loose and installed in field
 - hinged doors equipped with eye for customer-supplied padlock
- Panel mounted faucet or pot filler
- Flat top in lieu of peaked top on horizontal chase
- Ventilation control panel mounted in tower
- Filtered water system