

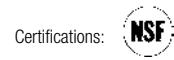

STEAM JACKETED KETTLES

DIRECT STEAM TABLE TOP TILTING KETTLE MODELS TDA/1

Kettle shall be Groen Model TDA/1-40 and TDA/1-48 quart stainless steel, 2/3 steam jacketed unit operating from direct steam.



PROJECT NAME:	
LOCATION:	
ITEM NO:	
QTY:	
MODEL NO:	
AIA NO:	
SIS NO:	
CSI SECTION:	11400



AVAILABLE MODELS:

- TDA/1-40 (40 QUART)
- TDA/1-48 (48 QUART)

CONSTRUCTION: Kettle proper shall be of 304 stainless steel, solid one piece welded construction. Support arms are heavy chrome plated steel tubing. Rim shall be reinforced with a welded butterfly shaped pouring lip, for pouring control and durability. Kettle shall have a right side handle for controlled pouring of kettle contents, and rear leg which stops kettle in upright position.

FINISH: Interior of kettle shall be polished to a 180 emery grit finish. Exterior of kettle shall be finished to a bright high buff finish, ensuring maximum ease in cleaning and maintaining brilliant appearance.

ASME CODE: Unit shall be ASME shop inspected, stamped and registered with the National Board for operation up to a maximum working pressure of 55 PSI.

SANITATION: Unit shall be designed and constructed to meet NSF requirements and be NSF listed.

STEAM PRESSURE: Kettles shall operate dependably at any steam pressure between 5 and 55 PSI. Higher working pressure available.

PERFORMANCE/FEATURES: Pouring height shall be such that kettle can be emptied into an 8" high pan on a flat table. Design shall make it easy for one person to precisely tilt kettle, when filled to capacity. All sizes have full bottom hemisphere steam jacket, for rapid product heating.

MOUNTING: Kettle shall be mounted on sturdy cast, chrome plated stainless steel arms. The steam supply shall enter through the left kettle support arm, through an integrated steam control valve into the jacket at the rotary joint, down through the support arm. No exposed steam piping shall be on the kettle body.

INSTALLATION: Steam trap assembly is required and not provided unless ordered as an option. 3/8" NPT steam inlet and condensate outlet required. Safety valve and remote steam source required.

OPTIONS/ACCESSORIES:

- Etch marks, gallons
- Etch marks, liters
- 316 stainless steel liner
- Basket insert
- Nylon basket liner
- Liner retaining ring
- Lift off cover
- Cover strainer
- Stand
- Steam trap assembly
- Pressure relief valve
- Globe valve
- Steam pressure regulator
- Cabinet base
- Table top stand

ADDITIONAL RESOURCES:

- [Request A Quote](#)
- [Sales Tools](#)
- [Find A Rep](#)

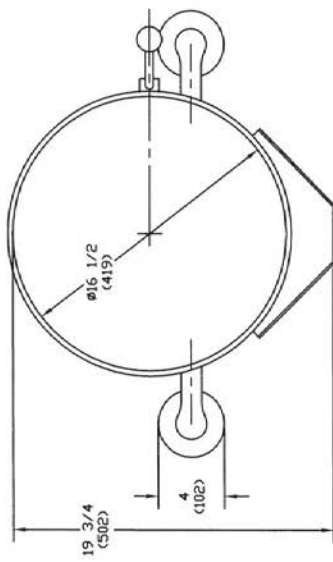
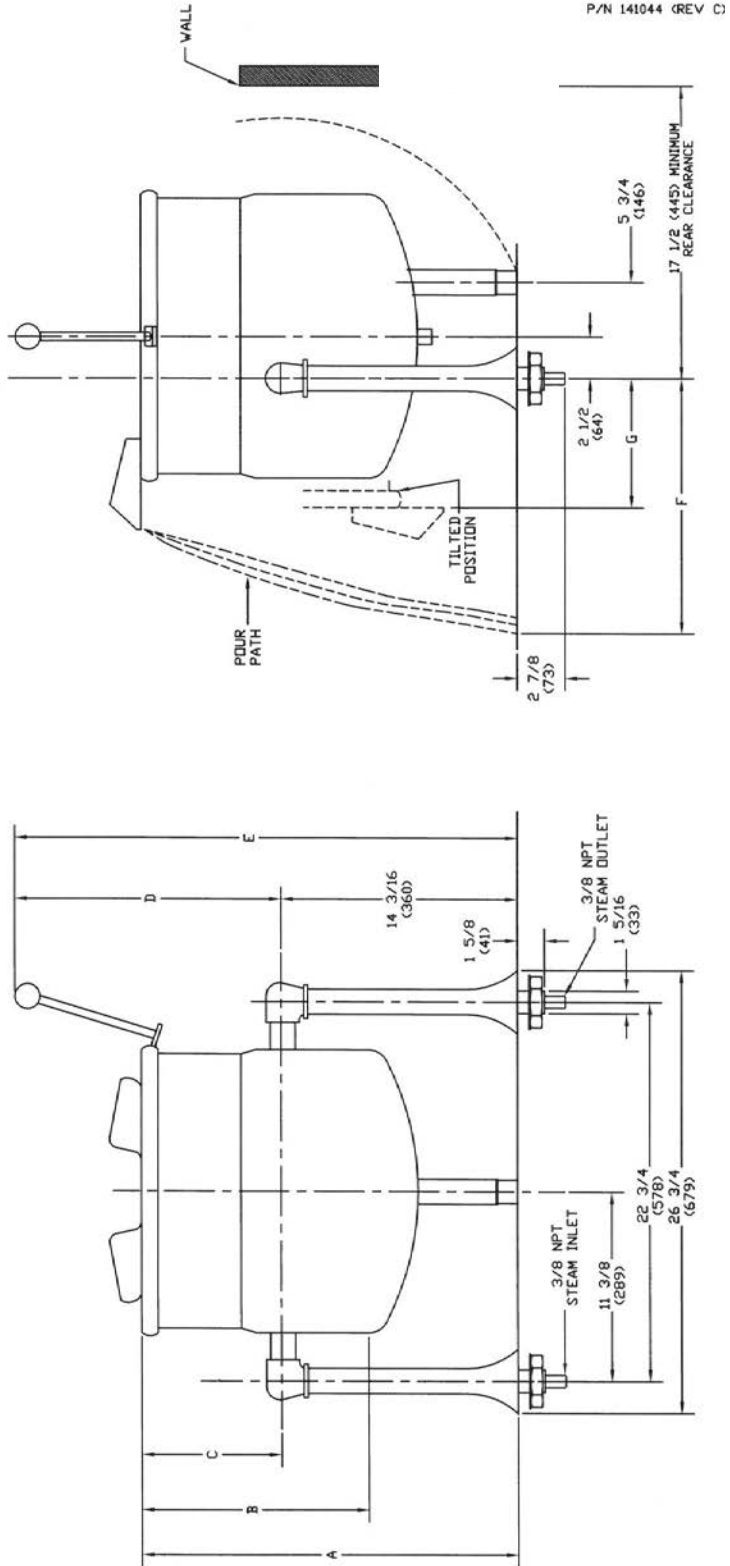

TABLE OF DIMENSIONS

DIM.	40 QT. (37.8L)		48 QT. (45.4L)	
	IN	MM	IN	MM
A	22 3/8	(568)	24 5/8	(625)
B	14 1/2	(368)	16 3/4	(425)
C	8 3/16	(208)	10 7/16	(265)
D	16 3/4	(425)	19	(483)
E	30 15/16	(786)	33 3/16	(843)
F	16	(406)	18 1/4	(464)
G	8 3/8	(213)	10 5/8	(270)

- NOTES:**
1. DIMENSIONS ARE IN INCHES; BRACKET(S) ARE IN MM.
 2. EXTENDED STEM GLOBE VALVE & COLLARED SLEEVE FURNISHED AT EXTRA COST. SEE DWG.C-7059-2 & PIPING INSTALLATION DETAILS.



P/N 141044 (REV C)

TDA/1-40 Shown