



STEAM JACKETED KETTLES

DIRECT STEAM TILTING FLOOR KETTLE MODELS DL

Kettle shall be a Groen Model DL (Specify 20, 40, 60 or 80-gallon) stainless steel, 2/3 steam jacketed unit operating from direct steam.

Certifications:

PROJECT NAME:	
LOCATION:	
ITEM NO:	
QTY:	
MODEL NO:	
AIA NO:	
SIS NO:	
CSI SECTION:	11400



AVAILABLE MODELS:

- DL-20 (20 GALLON)
- DL-40 (40 GALLON)
- DL-60 (60 GALLON)
- DL-80 (80 GALLON)

CONSTRUCTION: Kettle interior shall be of type 316 stainless steel with solid one-piece welded construction. Kettle jacket shall be 304 stainless steel, solid one piece construction. Unit shall be furnished with a heavy reinforced bar rim with a heavy-duty, butterfly-shaped pouring lip welded to the top rim of kettle to ensure proper pouring control at all times and to allow the kettle to be used to its full working capacity and for maximum sanitation and durability.

Kettle body shall be supported by a stainless steel yoke stand with tubular leg supports. Self-locking worm gear tilt mechanism and rotary steam joint are completely enclosed in stainless steel housing, mounted on the right kettle support arm. Large hand crank provides easy operator tilting and precise pouring control. Faucet mounting bracket is standard.

FINISH: Kettle interior shall be polished to a 180 emery grit finish. Exterior of kettle shall be finished to a semi-deluxe buff finish, ensuring maximum ease in cleaning and maintaining brilliant appearance.

ASME CODE: Unit shall be ASME shop-inspected, stamped and registered with the National Board for operation up to a maximum working pressure of 25 PSI.

SANITATION: Unit shall be designed and constructed to be NSF-listed, meeting NSF and all known health department and sanitation codes.

COVER: A cover is optional. No. 31 lift-off cover available for 20 to 80-gallon models. No. 51 counter-balanced cover available on 40 to 80-gallon models.

STEAM PRESSURE: Kettle shall operate dependably at any steam pressure between 5 and 25 PSI. Higher working pressures available.

MOUNTING: Kettle shall be trunnion-mounted to a sturdy stainless steel tubular leg stand with adjustable floor flanges.

INSTALLATION: Remote steam source required. Steam trap assembly is required and not provided unless ordered as an option. (See below) See dimension H on other side for steam inlet size and number.

OPTIONS/ACCESSORIES:

- Basket Inserts (TRI-BC)
- Water fill faucets (single or double pantry)
- Lift off cover
- Counterbalanced hinged cover kit
- 2" or 3" tangent draw-off valve
- Cold water cooling
- Steam trap assemblies
- Kettle brush kit
- 1/8" perforated disc strainer
- 1/4" perforated disk strainer
- Solid disc strainer
- Lip strainers
- Pan carrier (40 and 60-gallon)
- Contour measuring strip
- Gallon etch marks
- Contour measuring strip
- Gallon etch marks

ADDITIONAL RESOURCES:

- [Request A Quote](#)
- [Sales Tools](#)
- [Find A Rep](#)

TABLE OF DIMENSIONS									
CAPACITY (GALLONS/LITRES)									
	20/76		40/152		60/228		80/304		
	INCHES	MM	INCHES	MM	INCHES	MM	INCHES	MM	
A	20	508	26	660	30	762	32	813	
B	18 1/2	470	22	559	25	635	29	737	
C	36	914	36	914	44	1118	48	1219	
D	13	330	17	432	19	483	20	508	
E	20 1/8	511	23 3/4	603	25 3/4	654	26 3/4	680	
F	16 1/2	410	19 1/4	489	21 1/4	540	22 1/4	565	
G	23 5/8	600	23 1/2	597	29 1/4	743	31 1/4	794	
H	3/4	19	3/4	19	3/4	19	3/4	19	
J	3/4	19	3/4	19	3/4	19	3/4	19	
K	10 5/8	270	6 1/2	165	10 1/4	260	11 1/4	286	
L	21	533	32	813	31	787	31	787	
M	12 1/8	313	15 5/8	399	17 1/8	440	18 3/4	476	
N	13 3/8	340	15	381	16 3/4	426	16 3/4	426	
P	9 1/2	241	12 1/2	317	12	305	13	330	
R	12 1/2	317	13 1/2	343	14 1/2	368	13 3/4	349	
S	15	381	11 1/2	292	16 1/2	419	16 1/2	419	
T	14 3/4	375	11 1/4	286	16 1/4	413	16 1/4	413	
U	36 1/4	921	43	1092	47	1194	49	1245	
V	28 3/8	733	34 1/2	876	38 1/4	972	39 1/4	997	
W	12 3/8	314	12 1/2	318	14 3/4	375	16 3/4	426	

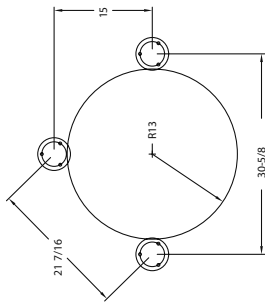

LEG LOCATION

NOTES

1. APPROX. 5 PSI. REQD. TO PUSH CONDENSATION UP DRAIN TUBE.
2. LEG FLANGES MUST BE SECURELY ANCHORED TO THE FLOOR.
- * 3. DIMENSIONS R & T REFER TO KETTLES WITH 2" DRAW-OFF VALVE.

OPTIONAL
2" OR 3" COMPRESSION DRK.
TYPE SANITARY DRAW-OFF VALVE
FURNISHED WHEN SPECIFIED AT EXTRA COST (SEE NOTE 3)

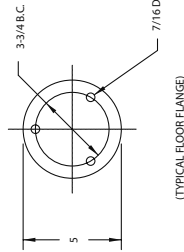
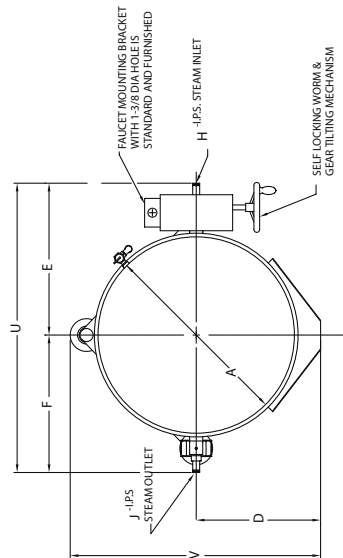

(TYPICAL FLOOR FLANGE)

