



TILTING FLOOR KETTLE

GAS MODELS DH-20/25/30/40/60(C/A/C2T)

Kettle shall be a Groen Model DH (specify gallon capacity and Classic (C), Advanced (A) or Cook2Temp™ (C2T) controls) stainless steel floor model manual tilting steam jacketed unit, operating with a self-contained gas heated steam source contained within the unit. Cook2Temp models also come with a probe.

PROJECT NAME:	
LOCATION:	
ITEM NO:	
QTY:	
MODEL NO:	
AIA NO:	
SIS NO:	
CSI SECTION:	

AVAILABLE MODELS:

CLASSIC CONTROLS:

- DH-20C (20 GALLON)
- DH-25C (25 GALLON)
- DH-30C (30 GALLON)
- DH-40C (40 GALLON)
- DH-60C (60 GALLON)

ADVANCED CONTROLS:

- DH-20A (20 GALLON)
- DH-25A (25 GALLON)
- DH-30A (30 GALLON)
- DH-40A (40 GALLON)
- DH-60A (60 GALLON)

COOK2TEMP CONTROLS:

- DH-20C2T (20 GALLON)
- DH-25C2T (25 GALLON)
- DH-30C2T (30 GALLON)
- DH-40C2T (40 GALLON)
- DH-60C2T (60 GALLON)

CONSTRUCTION: Kettle interior shall be of type 316 stainless steel, solid one-piece welded construction. The console and all exposed surfaces shall be stainless steel. All controls shall be mounted in a water resistant IPX6-rated enclosure right of the kettle body. The kettle body shall be mounted in a heavy-duty stainless steel combination kettle support tilt trunnion, supported by the stainless steel enclosed base. The base shall have stainless steel tubular legs with height adjustable bullet feet. The trunnion support base shall contain a smooth operating, self locking manual crank tilt mechanism, accessible for installation or maintenance. Kettle body shall have a heavy reinforced bar rim with a welded in butterfly shaped pouring lip for maximum sanitation and durability. Faucet mounting bracket is standard.

FINISH: Kettle interior shall be polished to a 180 emery grit finish. Exterior of kettle shall be finished to a bright high buff finish, ensuring maximum ease in cleaning and maintaining brilliant appearance.

ASME CODE, CSA DESIGN CERTIFIED:

Unit shall be ASME shop inspected, stamped and registered with the National Board for operation up to a maximum working pressure of 50 PSI. Unit shall be design certified by CSA International. (Natural and Propane only.)

SANITATION: Unit shall be designed and constructed to meet NSF and known health department and sanitation codes and be NSF listed.

DRAWOFF: A 2" tangent drawoff is optional. If drawoff is specified, outlet shall be equipped with removable 1/4" perforated stainless steel strainer.

SELF-CONTAINED STEAM SOURCE:

Kettle shall have a gas-heated (natural, butane, propane) self-contained steam system to provide kettle temperatures of 100 to approximately 287°F. Unit shall be factory charged with chemically-pure water and rust inhibitors to ensure long life and minimum maintenance.

CONTROLS: Controls to be located in right-side water resistant (IPX6-rated) trunnion enclosure:

Classic -C Models include: Power ON-OFF switch with indicator light, temperature control knob with 1 to 10 increments, HEAT(ing) indicator light and LOW WATER warning light; **Advanced -A Models** include: Same control features as Classic models with the addition of temperature and time set knob, LED display of set heat level or cook time, buttons for reset of Low Temp and High Temp presets, MANUAL mode button for knob-setting of heat level, TIMER-set button with indicator light; **Cook2Temp -C2T Models** include: Same control features as Classic and Advanced models with the addition of Auto C2T and Manual C2T buttons with core probe connection port, MANUAL mode button for knob-setting of heat level for manual cooking and manual C2T cooking.

SAFETY SYSTEMS: Safety systems to include kettle-mounted: pressure-vacuum gauge, pressure relief valve, pressure limit control, water sight glass; plus low-water cutoff, gas regulator valve and kettle tilt automatic gas shutoff.

PERFORMANCE FEATURES: Patented fin tube burner assembly delivers 62-65% efficient combustion, depending on size. 20 & 25 gallon models have 72,000 BTU/HR firing rate with 44,140 BTU/HR into the product; 30 & 40 Gallon models have 100,000 BTU/HR firing rate with 65,000 BTU/HR into the product, and 60 Gallon Model has 150,000 BTU/HR firing rate with 93,000 BTU/HR into the product. Electronic ignition to standing pilot is standard.

INSTALLATION: Specify natural, propane, butane, or specific propane/butane mixture. Unit requires 1/2" IPS gas line connection and 115 volt electrical connection. No remote steam source required.

ORIGIN OF MANUFACTURE: Designed and manufactured in the United States.



DH-20C Model shown with options

OPTIONS/ACCESSORIES:

- 2" tangent draw-off valve with 1/4" perforated disk strainer
- 1/8" perforated disk strainer
- 1/4" perforated disk strainer
- Solid disk strainer
- Basket inserts (TRI-BC)
- Lift-off cover (No. 31)
- Hinged cover kit (No. 51)
- Pan carrier (40 and 60-gallon)
- Kettle brush kit
- Single or double pantry faucets
- Lip strainer
- Contour measuring strip
- Gallon etch marks
- Replacement core probe (on C2T models only)

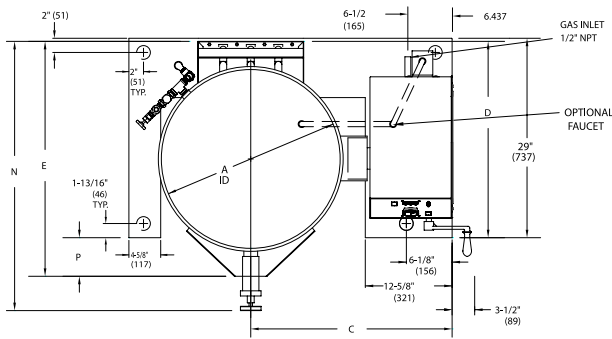

TOP VIEW

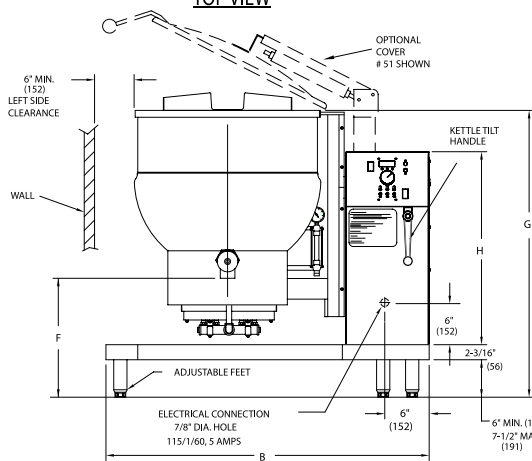

FRONT VIEW

DIMENSIONS

CAPACITY	20 Gal.		25 Gal.		30 Gal.		40 Gal.		60 Gal.	
	DIMS	INCH	MM	INCH	MM	INCH	MM	INCH	MM	MM
A	20	508	20	508	26	660	26	660	30	762
B	35	889	35	889	47	1194	47	1194	47	1194
C	26	660	26	660	29	737	29 1/2	749	29 1/2	784
D	31	787	31	787	26 1/2	673	26 1/2	673	35 1/2	902
E	32 3/4	832	32 3/4	832	34 5/8	879	34 5/8	879	42 7/8	1089
F	18	457	15	381	19 1/2	495	18 1/4	463	19	483
G	39 3/8	1000	40 5/8	1032	40 1/8	1019	43 1/8	1095	46 1/4	1175
H	26	660	28	711	26	660	28	711	28	711
J	15 5/8	397	17	432	11	279	13 3/4	349	12 3/8	314
K	27	686	28	711	29 1/2	749	29 1/4	743	35	889
L	30 1/4	768	30 1/4	768	31	787	31	787	31 3/4	806
M	51	1295	53	1346	59 1/2	1511	60 1/2	1537	61 1/2	1562
N	37 1/4	946	37 1/4	946	36 1/8	918	36 1/8	918	43 1/8	1095
P	2	51	2	51	5 7/16	138	5 7/16	138	7 1/2	191

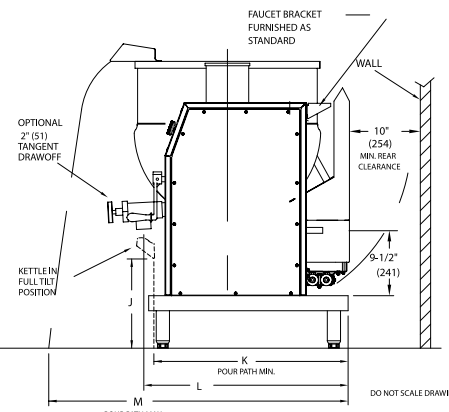

RIGHT SIDE VIEW



CLASSIC CONTROL



ADVANCED CONTROL



COOK2TEMP CONTROL

INCOMING GAS PRESSURE TABLE			OPERATING GAS PRESSURE	
TYPE OF GAS	MIN. SUPPLY GAS PRESSURE	MAX. SUPPLY GAS PRESSURE	NATURAL	PROPANE
NATURAL	4.5 W.C.	14.0 W.C.	3.5 W.C.	10.0 W.C.
PROPANE	11.0 W.C.	14 W.C.		

- NOTES:**
- OPTIONAL EXTRA COST FEATURES:**
- 2" TANGENT SANITARY DRAW-OFF
 - LIFT OFF COVER MODEL # 31 FOR DH-20, DH-25 & DH-30 KETTLES
 - HINGED COVER MODEL # 51 FOR DH-40 & DH-60 KETTLES
 - FAUCET WITH SWING SPOUT
 - DIMENSIONS IN BRACKETS () ARE MM

PERFORMANCE DATA

Model	Kettle Capacity	Kettle Body Diameter	Base Width	Base Depth	Firing Rate Per Hour	Energy into Product Per Hour
DH-20 (C,A,C2T)	20 Gal.	20 inches	35 inches	29 inches	72,000 BTU	44,140 BTU
	75 Liter	508 mm	889 mm	736 mm		
DH-25 (C,A,C2T)	25 Gal.	20 inches	35 inches	29 inches	72,000 BTU	44,140 BTU
	95 Liter	508 mm	889 mm	736 mm		
DH-30 (C,A,C2T)	30 Gal.	26 inches	47 inches	29 inches	100,000 BTU	65,000 BTU
	114 Liter	660 mm	1194 mm	736 mm		
DH-40 (C,A,C2T)	40 Gal.	26 inches	47 inches	29 inches	100,000 BTU	65,000 BTU
	150 Liter	660 mm	1194 mm	736 mm		
DH-60 (C,A,C2T)	60 Gal.	30 inches	47 inches	29 inches	150,000 BTU	93,000 BTU
	225 Liter	762 mm	1194 mm	736 mm		