



COOK-CHILL SYSTEMS

GAS TILTING KETTLE MODEL DH-100

CapKold® Model DH-100 gallon working capacity, self-contained, high efficiency 360,000 BTU/hr gas fired, hemispheric bottom steam jacketed kettle. Electrically driven worm gear tilts kettle body to simplify product loading, kettle cleaning and transfer of non-pumpable products. 50 PSI maximum jacket operating pressure, 3" air operated drop down outlet valve.

PROJECT NAME:

LOCATION:

ITEM NO:

QTY:

MODEL NO:

AIA NO:

SIS NO:

CONSTRUCTION

- 50 PSI, ASME Code hemispheric bottom kettle jacket construction and National Board registered
- C.S.A. Design Certified and NSF listed
- High efficiency fin tube gas heat exchanger with 360,000 BTU/hr maximum power input
- Reinforced bar rim and flow control pouring lip
- Electrically driven worm gear tilt of kettle body for pouring and cleaning
- Electronic ignition
- 3" air operated drop down stainless steel outlet valve mounted flush to kettle bottom
- Type 316 stainless steel kettle interior and all wetted parts, type 304 elsewhere
- 3/4" rim mounted water fill faucet
- Compressed air connection for CapKold® Pump/Fill Station (see CKPF/3)
- 100 gallon working capacity
- NSF listed

INTEGRAL CONTROL PACKAGE:

- Android touch screen comes with English or Spanish, Gallons or Liters, and Fahrenheit or Celsius at a touch
- Digital product temperature indicator/controller
- Pilot light indicator
- Power ON indicator light
- Kettle body tilt switch and indicator
- Low water (kettle jacket) indicator light
- Pre-set automatic water metering with real time display

ORIGIN OF MANUFACTURE: Designed and manufactured in the United States.



OPTIONS/ACCESSORIES:

- Product temperature paperless chart recorder saves data as a PDF
- 2 piece hinged cover
- Removable pouring lip mounted product strainer
- Prison package

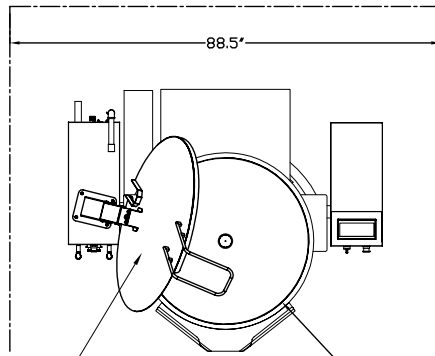
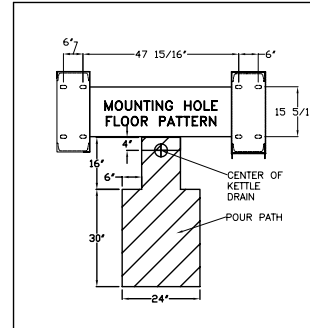
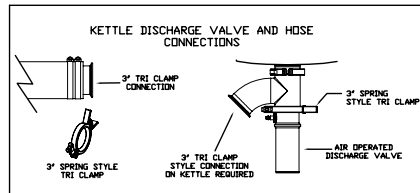
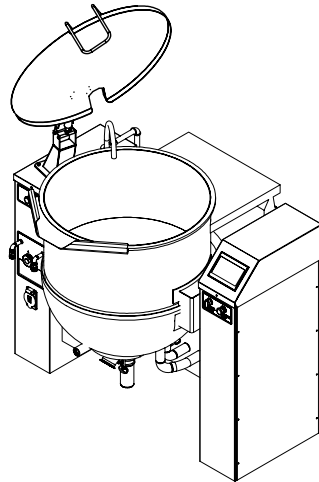

#51 POWER AID COVER

PRODUCT SPECIFICATIONS:

1. ALL DIMENSIONS ARE EQUIPMENT DIMENSIONS
 2. INPUT RATE: MAX 300,000 BTU/HR
 3. ELECTRICAL SUPPLY VOLTAGE:
208/5/60 – 11 AMPS – 20 AMP SERVICE
ELECTRICAL CONNECTION 1/2" CONDUIT
 4. TOUCH SCREEN CONTROL
 5. 1" NPT GAS SUPPLY
- | INCOMING GAS SUPPLY PRESSURES | | |
|-------------------------------|---------|----------|
| GAS TYPE | MINIMUM | MAXIMUM |
| NATURAL | 7" W.C. | 14" W.C. |
6. 50 PSI ASME APPROVED
 7. NO AGITATOR
 8. ELECTRIC MOTOR DRIVEN POWER TILT FEATURE
 9. APPROX. SHIPPING WEIGHT: 1550 LBS
 10. COLD WATER SUPPLY – 3/4" HOSE CONNECTION
10 GPM @ 30 PSI
(SUPPLY 30 PSI MIN. & 60 PSI MAX.)
 12. 12" SERVICE CLEARANCE REQUIRED
 13. UNIT MUST BE MOUNTED ON NON-COMBUSTIBLE FLOORING AND SEALED AT BASE WITH CAULKING.

