



STEAM JACKETED KETTLES

LOW HEIGHT GAS STATIONARY FLOOR KETTLE MODEL AHS-40

Kettle shall be a Groen Model AHS (40 gallon) stainless steel, self-contained, steam jacketed kettle operating from gas heated steam source contained within the unit.



PROJECT NAME:	
LOCATION:	
ITEM NO:	
QTY:	
MODEL NO:	
AIA NO:	
SIS NO:	
CSI SECTION:	11400



CONSTRUCTION: Kettle interior shall be of type 316 stainless steel, with solid one-piece construction. All exposed surfaces shall be stainless steel. All controls shall be contained within front control enclosure. Kettle body is sheathed in stainless steel and insulated with fiber bat insulation. Unit provided with three adjustable legs for leveling. Faucet mounting bracket is standard.

FINISH: Interior of kettle shall be polished to a 180 emery grit finish. Exterior shall be finished to a uniform #3 finish ensuring maximum ease in cleaning and maintaining appearance.

ASME CODE, CSA DESIGN CERTIFIED, CRN REGISTERED: Unit shall be ASME shop inspected, stamped and registered with the National Board for operation up to a maximum working pressure of 30 PSI. Unit shall be Design Certified by CSA International and registered in Canada with a CRN number.

SANITATION: Unit shall be designed and manufactured to meet NSF requirements and be NSF listed.

DRAWOFF VALVE: Unit shall have a 2" sanitary tangent drawoff which is made of 316 stainless steel. Valve has durable insulated handle, Dupont Viton™ compression sealing disk and is easy to disassemble without tools. The drain outlet shall be equipped with a removable 1/4" perforated stainless steel strainer.

COVER: Cover shall be furnished with No. 51 counterbalanced actuator designed to maintain the cover in an open or closed position.

CONTROLS: All controls shall be contained in a stainless steel enclosure. Controls include a regulating thermostat, pressure gauge, power-ON switch, power-ON indicator light, heat indicator light, low water indicator light, water sight gauge, pressure safety valve, pressure limit control, low water cut off, a gas regulator valve and electronic ignition module; with all operating controls front mounted.

PERFORMANCE/FEATURES: Unit shall be thermostatically controlled to automatically shut off when desired temperature is reached and turn on when product temperature drops below desired setting. Electronic ignition to standing pilot is standard. Outer sheathing and fiber insulation retain heat and keep kettle exterior cool to the touch.

SELF-CONTAINED STEAM SOURCE: Kettle shall have a gas-heated, self-contained steam source to provide kettle temperatures of 150 to approximately 250°F. Unit shall be factory charged with water and rust inhibitor to ensure long life and minimum maintenance.

INSTALLATION: Specify natural or propane. Unit requires 1/2" NPT gas line connection and 115 volt electric supply to operate controls. No remote steam source required.

OPTIONS/ACCESSORIES:

- Basket inserts (TRI-BC)
- Water fill faucets
- 1/8" perforated strainer
- 1/4" perforated strainer
- Solid disk strainer
- Kettle brush kit
- Contour measuring strip
- Gallon etch marks

ADDITIONAL RESOURCES:

- [Request A Quote](#)
- [Sales Tools](#)
- [Find A Rep](#)

TABLE OF DIMENSIONS		
CAP.	40 GAL. 150 L.	
DIM.	INCH	MM
A	26	660
B	32.3/8	822
C	30.3/8	772
D	27 1/8	638
E	54 1/4	1327
F	43 1/4	1099
G	25	635
H	38	965
J	7	178
K	15	381
L	6	152
M	71.3/4	1822
N	6	152
P	21.3/8	543
R	21	533

INSTALLATION CLEARANCES		RECOMMENDED DISTANCE
MINIMUM DISTANCE FROM COMBUSTIBLE WALLS		
LEFT SIDE	2"	2"
RIGHT SIDE	2"	8" FOR SERVICING
REAR	4"	4"

GAS OPERATING PRESSURE	NATURAL GAS	PROPANE GAS
RECOMMENDED INCOMING PRESSURE	3.5" W.C.	10" W.C.
FIRING RATE	5" W.C. MIN. 14" W.C. MAX.	12" W.C. MIN. 14" W.C. MAX.
	115,000	115,000

SERVICE CONNECTIONS AND NOTES:
 1. ELECTRICAL CONNECTION: 115V, 1 PH, 60 HZ, 2 AMPS
 2. GAS CONNECTION: 1/2" NPT.
 3. DIMENSIONS IN BRACKETS () ARE MM.

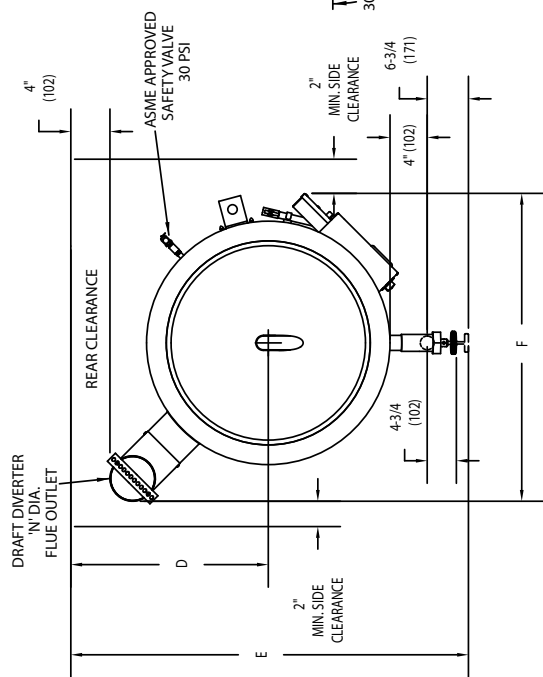
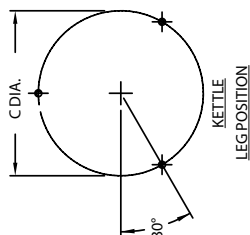

TOP VIEW

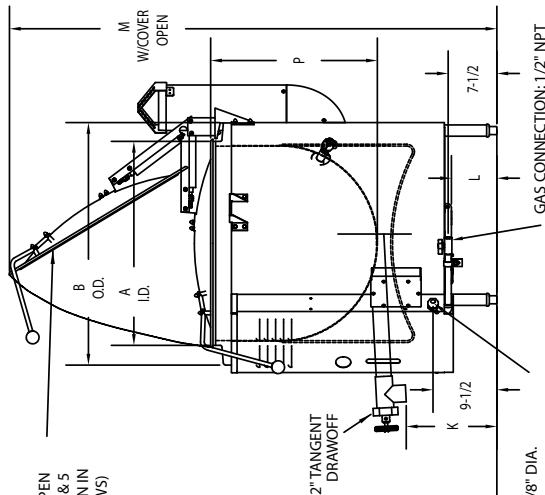

RIGHT SIDE VIEW

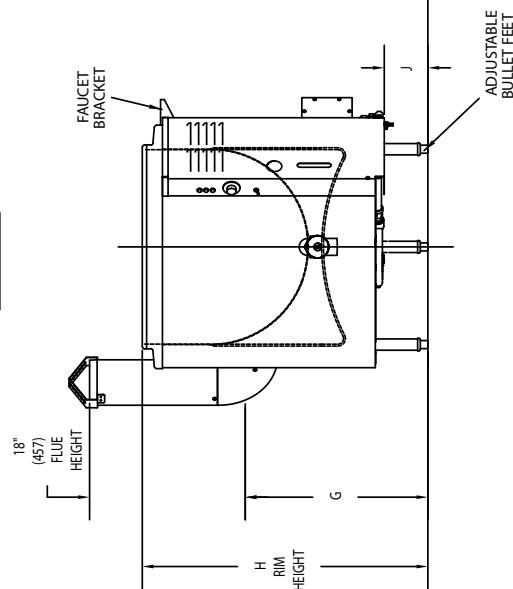

FRONT VIEW

SCALE: 04=1
DO NOT SCALE DRAWING

139158 REV. A