



STEAM JACKETED KETTLES

TWO KETTLES WITH GAS STEAM BOILER CABINET BASE

MODEL (2)CTDC/3-20-SG

Unit shall be a Groen Model (2)CTDC/3-20-SG, with two 20 quart stainless steel tilting steam jacketed kettles, with cabinet mounted gas steam boiler, per Bulletin 34Hd and as follows.



PROJECT NAME:	
LOCATION:	
ITEM NO:	
QTY:	
MODEL NO:	
AIA NO:	
SIS NO:	
CSI SECTION:	11400



CONSTRUCTION: Kettles shall be Type 304 stainless steel with solid one-piece welded construction, with tubular stainless steel support arms. Rim shall be triple reinforced to resist abuse, with a welded "Butterfly" shaped lip, for easy pouring. Kettles shall have two operating handle lugs so that handle can be attached on right or left side. 36" wide cabinet base shall have stainless steel frame, top deck, double panel access doors, side and rear panels and 6" legs. Front legs shall be adjustable bullet feet while back legs shall have adjustable flanged feet. Cabinet design and trim shall match other HyPLUS™ modular equipment.

FINISH: Cabinet base shall be finished to a #3 uniform finish. Kettle exteriors shall be polished to a bright high buff finish. Accent strip shall be matt finish polyester film ensuring maximum ease in cleaning and maintaining an attractive appearance.

ASME CODE & UL APPROVAL: Cabinet mounted steam generator shall be ASME Code constructed and National Board registered for operation up to 15 PSI. Kettles shall be coded and registered for operation up to 55 PSI. Gas boiler is AGA design certified.

SANITATION: Unit shall be designed and manufactured to meet NSF known health department and sanitation codes and be NSF listed.

SINKS/FAUCET: Unit shall have one large flush mounted pouring sink mounted in front of both kettles. Sink shall be piped to common drain and provided with a removable anti-splash screen. Unit comes standard with hot and cold water faucet with swing spout.

CONTROLS: Gas pressure boiler shall be provided with a gas control valve, power-ON switch, reset light, start switch, exterior mounted pressure gauge, water level sight glass, low water sensor and pop safety valve. Kettle steam control valves and hot and cold water faucets are front mounted for easy access.

PERFORMANCE FEATURES: Unit will shut off if water level is too low or unit builds too much pressure. When power switch is turned "off," the boiler automatically drains to reduce sediment build-up, after water has cooled to 170°F. Kettles shall operate dependably at any steam pressure between 5 and 55 PSI.

CABINET BASE STEAM SOURCE: Unit shall have a gas heated cabinet mounted steam boiler to provide approximately 10 PSI steam to the kettles. ASME Code constructed and National Board registered for operation up to 15 PSI. 200,000 BTU boiler delivers to 120,000 BTU/hr into the product, is 60% efficient and delivers 3.7 boiler horsepower. Electronic ignition is standard. Auxiliary manual drain valve to simplify maintenance is also included.

INSTALLATION: Unit requires gas service via 1/2" NPT pipe or approved equivalent. Unit requires 3/8" NPT hot and 1/2" NPT cold water supply lines. Requires single free venting 1 1/4" NPT drain for automatic and manual drain for kettles and sink, and 115 Volt, 60 HZ single phase. 15 AMP electrical service. Kettles are completely pre-piped to gas boiler.

STEAM SOURCE FOR OTHER EQUIPMENT: If additional equipment (steam kettle, etc.) is to be powered by boiler, a power take-off valve is provided. To ensure proper performance, boiler must be properly sized to meet boiler horsepower requirements of kettles AND additional equipment.

WATER SUPPLY REQUIREMENTS: All water boiler systems are subject to contamination and failure due to mineral content found in most water supplies. To minimize service problems, a water treatment (softening) system is recommended when water quality is found to exceed limits stated below and in operator manual. Recommended MINIMUM water quality standards are: total dissolved solids (TDS) content should not exceed 30 parts per million; and the water pH should be 7.0 or higher.

OPTIONS/ACCESSORIES:

- Lift-off covers for kettles
- Basket insert for kettles
- Basket inserts and brush kits for kettles

ADDITIONAL RESOURCES:

- Request A Quote
- Sales Tools
- Find A Rep

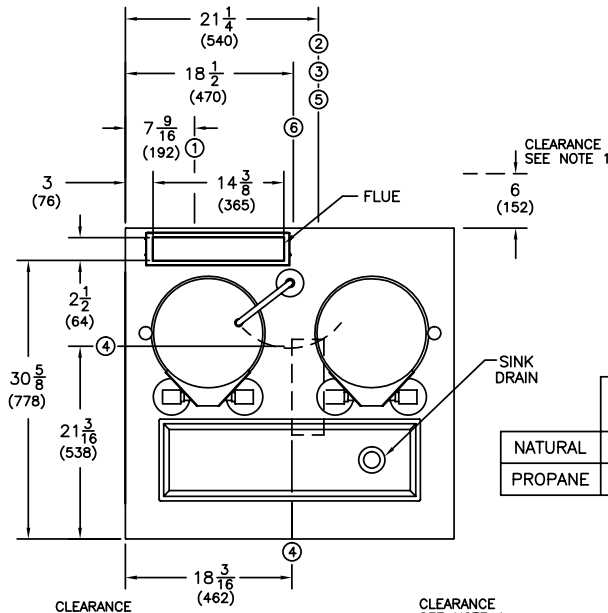

	RECOMMENDED INCOMING GAS PRESSURE *		OPERATING GAS PRESSURE *
NATURAL	5" W.C. (MIN.)	14" W.C. (MAX.)	3.5" W.C.
PROPANE	11" W.C. (MIN.)	14" W.C. (MAX.)	10.0" W.C.

* INCHES WATER COLUMN

INPUT RATE (BTU/HR.): 200,000
 OUTPUT RATE (BTU/HR.): 120,000
 BOILER HORSEPOWER: 3.7

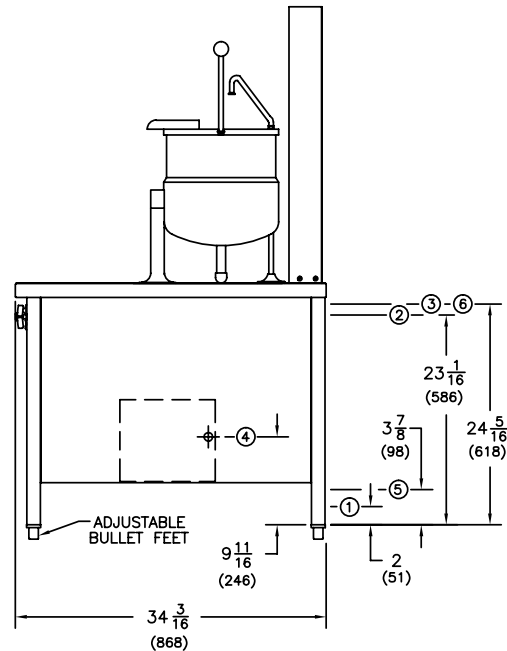
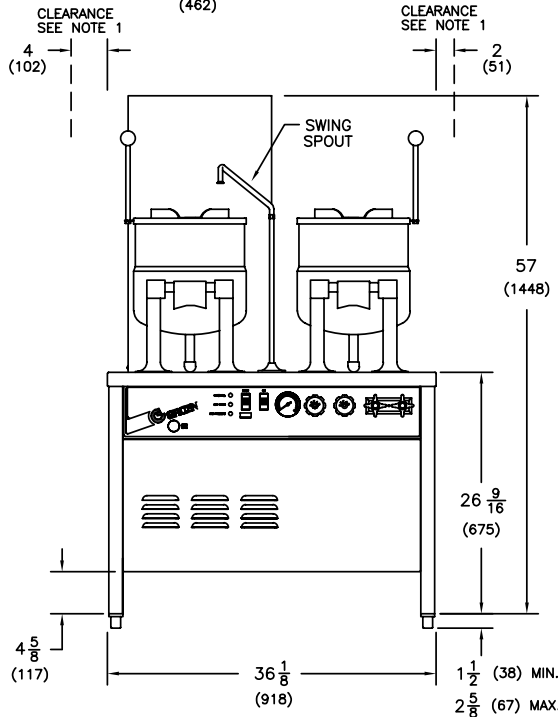

SERVICE CONNECTIONS:

- ① DRAIN CONNECTION: 1-1/4" NPT (INCLUDES AUTOMATIC & MANUAL BOILER, KETTLES & SINK)
- ② COLD WATER SUPPLY: 1/2" NPT (FOR BOILER & FAUCET)
- ③ HOT WATER SUPPLY: 3/8" NPT (FOR FAUCET)
- ④ ELECTRICAL CONNECTION: 7/8" DIA. HOLE (REF. 1/2" CONDUIT KNOCK-OUT)
- ⑤ GAS CONNECTION: 1/2" NPT
- ⑥ STEAM POWER TAKE-OFF: 1/2" NPT

NOTES:

- 1. MINIMUM CLEARANCE FROM COMBUSTIBLE MATERIALS
 RIGHT SIDE 2" (51)
 LEFT SIDE 4" (102)
 REAR 6" (152)
- 2. DIMENSIONS IN BRACKETS () ARE MILLIMETERS.
- 3. SPLASHGUARD SUPPLIED BUT NOT SHOWN.