



WATER TREATMENT SYSTEMS

WATER TREATMENT REVERSE OSMOSIS MODEL OP350/50

OP350/50 Water Treatment System utilizes reverse osmosis (RO) to remove >97% of the total dissolved solids (TDS) from water. Then a balance of minerals is dissolved into the RO water to provide desirable "Optimized" water TDS.

Certifications:

PROJECT NAME:	
LOCATION:	
ITEM NO:	
QTY:	
MODEL NO:	
AIA NO:	
SIS NO:	
CSI SECTION:	11400



STANDARD FEATURES: The system operates at line pressure and can produce up to 350 gallons per day of optimal quality water for applications where TDS reduction or the removal of the majority of hardness minerals is required. The OP350/50 is a complete system that includes integrated pre-filtration with particulate and chlorine reduction, reverse osmosis and mineral addition in a space saving, wall-mount or under counter design. Adjustable Reject Flow Control allows precise adjustment of Product/Reject Ratio. A built-in full system bypass valve and sample port assures no service interruption and simplifies routine maintenance. Also included is a 50-gallon atmospheric storage tank with a top-mounted variable-flow repressurization system and a sub-micron air breather. Hose, tubing and fittings required for installation are included.

APPLICATION: Any foodservice equipment where it is desirable to remove existing TDS and provide a consistent balance of buffered TDS to minimize problems associated with high TDS, high hardness, high chlorides or any other TDS-related problems.

INSTALLATION:

- Feed-water connection to system should be COLD only
- Do not exceed system specifications for temperature and pressure
- Provide a dedicated 1/2" water line to the unit for consistent flow and pressure to the system
- Allow 3" clearance below system for filter cartridge removal and replacement
- Connect filtered water line to steam production connections only — do not use for condenser water
- Detailed installation, operation and maintenance manual is included with each system
- Mount the OP350/50 where it can be easily serviced

BENEFITS:

- Virtually eliminates scale and corrosion problems related to high TDS and water hardness and reduce the potential for corrosion related to water chemistry
- The integrated QTMA mineral addition cartridge adds desirable TDS to provide balanced, buffered optimized water
- High capacity parallel pre-filtration protects the RO membrane and assures consistent performance for up to one year between pre-filter replacements
- Compact, modular design enables installation under counters and in very tight spaces
- Maximize equipment operating and energy efficiency
- Adjustable Reject Flow Control minimizes water use due to seasonal fluctuations in water temperature
- Dual-read digital TDS meter provides push-button monitoring of membrane performance and optimized water quality
- Sample Port allows quick and simple system checks and adjustments
- Built-in pressure gauge allows visual monitoring of operating pressure
- Integrated system bypass valve eliminates down-time or service interruptions
- All consumables are easy-to-change Qwik-Twist cartridges

OPTIONS/ACCESSORIES:

- QTPT-1 CTO Post-Treatment, Part No. 160-52120
- BPS-QT Booster Pump, Part No. 164-85020
- FXPT-11CR Chloramine Reduction System, Part No. 160-50011
- PRV Pressure Reducing Valve, Part No. 164-89938

ADDITIONAL RESOURCES:

- [Request A Quote](#)
- [Sales Tools](#)
- [Find A Rep](#)

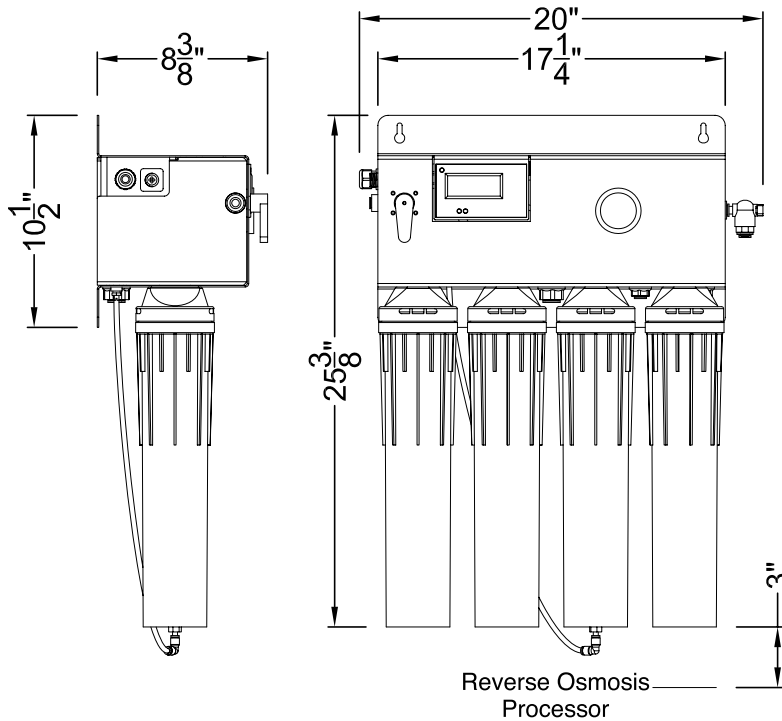

Reverse Osmosis Processor

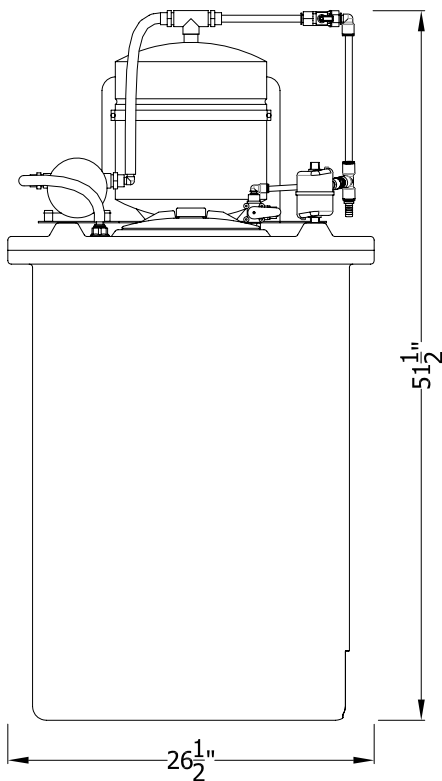

Re-pressurization/Storage Tank Assembly

Note: Re-pressurization Pump/ Buffer Tank Stand Assembly can be removed from top of tank and placed on floor or shelf in close proximity of the tank. Use Remote Kit PN: 164-89150.

Feed-Water Chemistry

Feed TDS	Up to 1200 ppm
Feed pH	6-10
Hardness*	12 grains or less
Free Chlorine	<2 mg/l
Iron	0.1 mg/l max
Turbidity	0.05 NTU
Manganese	0.05 mg/l max
Hydrogen Sulfide	0.0 mg/l

Specifications

System	
Dimensions	RO Processor 25.4”h x20”w x8.4”d Repressurization/StorageTank 51.5”h x 26.5” dia.
Connection - Feedwater	3/8” Push Fit Tubing
Operating Pressure Range	60-85 psi at 0.5 gpm (3.5 -5.9 bar)
Inlet Water Temperature Range	40° -100° F (4° -38° C)
Shipping Weight	25 lbs.
Drain Connection (Within 5’ of unit)	2 GPM Minimum Flow
Performance	
Typical TDS* Rejection	97+%
Product Water Production (at 77°F, 60psi) <i>Production rate is strictly dependent on feed water temperature and pressure.</i>	350 gals/day 14.6 gals/hr 0.25 gpm
Typical Optimized Water TDS	40-80 ppm

Replacement Media

Description	Part Number	Qty
CTO-Q Pre-Filters	300-05830	2
AMS-QT Membrane	204-53040	1
MA-Q15 Post-Treatment	300-05855	1

It is recommended that Pre-Filters and Mineral Addition Cartridge be changed every 6 months, when capacity is reached or when feedwater pressure or flow becomes inadequate. Membrane life varies depending on feedwater conditions and PreFilter maintenance. 12-18 months under typical conditions but it can be as long as 3-5 years.