



OPERATOR MANUAL

IMPORTANT INFORMATION, KEEP FOR OPERATOR

888-994-7636, fax 888-864-7636
unifiedbrands.net

THIS MANUAL MUST BE RETAINED FOR FUTURE REFERENCE. READ, UNDERSTAND AND FOLLOW THE INSTRUCTIONS AND WARNINGS CONTAINED IN THIS MANUAL.

NOTIFY CARRIER OF DAMAGE AT ONCE It is the responsibility of the consignee to inspect the container upon receipt of same and to determine the possibility of any damage, including concealed damage. Power Soak suggests that if you are suspicious of damage to make a notation on the delivery receipt. It will be the responsibility of the consignee to file a claim with the carrier. We recommend that you do so at once.

Manufacture Service/Questions 888-994-7636.

This manual provides information for:

POWER PREP UNLIMITED



INTRODUCTION AND CONVENTIONS

PRODUCT INTRODUCTION

Thank you for purchasing a Power Prep system. Your new Power Prep system will provide years of dependable, efficient and trouble-free service. Please note that photos and information referenced in this document are for the "Left to Right" unit. All information and methods of operation in this document is also intended for the "Right to Left" unit.

As a Power Prep Unlimited owner, you will benefit in numerous ways:

- Your deglazing operation will be more efficient.
- Your products will free of ice.
- Your produce will harbor fewer microbes.
- Your water usage will decrease.
- Your deglazing time will decrease and your employee morale will increase.

Every system is manufactured to last, with only high-quality, heavy-duty, 14 gauge stainless steel used in its construction. All electrical components used in a Power Prep Unlimited system are of the highest quality. The faucet and drain are designed for quick filling and emptying of the system's sink.

At Power Soak, we take pride in manufacturing the Power Prep Unlimited and are committed to standing behind our customers and products 100%. Should you ever need assistance, please contact us directly at the factory by dialing 888-994-7636 or fax: 601-371-9732.

PRODUCE WASHING CHEMICALS AND ANTIMICROBIALS

The produce wash product you select is best if it:

- Requires a minimal wash time, ideally, two minutes or less
- Requires no rinsing
- Is non-corrosive when properly diluted
- Is dispensed through fixed dilution rate equipment
- Is FDA and/or EPA approved for both whole and cut fruit and vegetables

Consult your chemical provider for a suitable product.

EXPLANATION OF WARNING MESSAGES

Read, understand and follow all DANGER, WARNING, and CAUTION messages located in this guide and on the equipment.



Danger

Personal Injury and Property Damage hazard.

May result in serious injury or death.

May cause extensive equipment damage.



Warning

Property damage hazard.

May result in property or equipment damage.

Do not stand, walk or sit on work surface top, drain boards or sinks.

Hazard from sharp objects, scalding, falling and/or drowning.

Will result in serious injury or death.

Power Soak, Inc. is not a manufacturer, importer, or distributor of antimicrobials.

Power Soak, Inc. does not make specific brand recommendations for these chemicals.



Chemical Hazard

May result in serious injury or death. Instructions, labels and Material Safety Data Sheets (MSDSs) should be supplied with all treating chemicals. The manufacturers, importers and distributors of your treating chemicals are responsible for providing this information.

EQUIPMENT DESCRIPTION

# of Bays	Model No.	Length	Voltage	Flow	FLOW CONFIGURATION				
					End Splash	Soiled Drain Board	Wash Tank	Clean Drain Board	End Splash
2	PPU2B-66L-208-1	66"	208/60/1	Left to Right	Hemmed	24"	18" x 19"	24"	Hemmed
	PPU2B-66L-230-1		230/60/1						
	PPU2B-66L-208-3		208/60/3						
	PPU2B-66L-230-3		230/60/3						
	PPU2B-66L-480-3		480/60/3						
	PPU2B-66R-208-1		208/60/1	Right to Left					
	PPU2B-66R-230-1		230/60/1						
	PPU2B-66R-208-3		208/60/3						
	PPU2B-66R-230-3		230/60/3						
	PPU2B-66R-480-3		480/60/3						

INSTALLATION



THE INSTALLATION AND INITIAL OPERATIONAL CHECK OF YOUR NEW SYSTEM MUST BE PERFORMED ONLY BY LICENSED AND CERTIFIED PLUMBERS AND ELECTRICIANS.



BE SURE TO FOLLOW ALL APPLICABLE NATIONAL AND LOCAL ELECTRICAL CODES WHEN INSTALLING THE ELECTRICAL SUPPLY AND/OR A NEW CIRCUIT BREAKER. DO NOT CONNECT THE SYSTEM USING A POWER CORD AND PLUG OR AN EXTENSION CORD OF ANY KIND.

ELECTRICAL REQUIREMENTS

Please refer to the detailed installation instructions that were sent with your Power Prep system.

The electrical requirements of your new system are on the serial number plate located on the end of the wash sink near the front, adjacent to the control panel enclosure. They are also shown inside the control panel enclosure itself.

All Power Prep systems have a single point electrical connection, and a dedicated circuit is required.

The system is completely pre-wired and tested at the factory, and a hard-wired connection from an appropriate power source is all that is required.

The installer is to provide a NEMA 3X disconnect that should be incorporated in the fixed wiring.

Properly sized watertight conduit, fittings and parts are required, as well as the appropriate gauge wire.

If your system is a "left-to-right" unit, you should locate the disconnect at the left end of the system. (The opposite would be true for a "right-to-left" system.)

Ideally, the disconnect should be located on the wall directly behind the pump motor and control panel provided this location is easily accessible by the operator and does not interfere with the faucet.

Specific part numbers and parts information can be obtained from the factory by calling 888-994-7636.

PLUMBING REQUIREMENTS

The Power Prep Unlimited unit will require the following plumbing connections:

- 3/4" (19mm) or 1/2" (12 mm) hot and cold water supply lines.
- Waste water connection (minimum 1 1/2" / 38mm).

LEVELING REQUIREMENTS

Your unit requires proper leveling to ensure proper operation, ease of disassembly/reassembly during cleaning, and proper drainage of sloped surfaces.

- Adjust leveling feet so the front and side rims are level and so that all leveling feet are bearing load.

OPERATING INSTRUCTIONS



BE SURE TO ADJUST KNOBS ON THE SPRAY RINSE AND ALL WATER FAUCETS SO THAT THE WATER TEMPERATURE IS BELOW 120°F (49°C). TEMPERATURES HIGHER THAN WHAT IS RECOMMENDED CAN CAUSE SCALDING IF CONTACT IS MADE WITH A PERSON'S SKIN.

DO NOT PLACE KNIVES OR OTHER SHARP OBJECTS IN THE POWER PREP. ALLOWING KNIVES OR OTHER SHARP OBJECTS TO TUMBLE FREELY IN THE POWER PREP TANK MAY CAUSE DAMAGE TO THE EQUIPMENT AND BODILY INJURY TO THE USER.

KEEP FINGERS OUT OF PORTS.

DO NOT USE ANY CLEANER THAT CONTAINS ANY SULFAMIC AGENT, OR ANY CHLORIDE, INCLUDING HYDROCHLORIC ACID (HCL) OR SODIUM HYPOCHLORITE.

DO NOT USE ANY CHEMICALS LISTED AS AN OXIDIZER.

TO CHECK FOR CHLORIDE CONTENT SEE THE SAFETY DATA SHEETS PROVIDED BY THE CLEANING AGENT MANUFACTURER.

DO NOT USE ANY CLEANING AGENT THAT CONTAINS MORE THAN 30% PHOSPHORIC ACID.

DISCONNECT ALL ELECTRICAL POWER FROM THE UNIT BEFORE ATTEMPTING TO DISASSEMBLE AND CLEAN THE PIPING AND THE PUMP.

EXERCISE EXTREME CARE WHEN HANDLING THE PIPING, CLAMPS AND PUMP COMPONENTS.



HAZARDOUS VOLTAGE INSIDE. DISCONNECT POWER BEFORE SERVICING. SERVICE BY TRAINED PERSONNEL ONLY.

PLACING THE WASH INSERT COMPONENTS

Begin by removing any debris left from previous batches of product. Disinfect all work surfaces according to the standard practices of your operation.



Rib Sets

Once the system is clean, the wash sink components can be installed. Begin by installing intake guard in the front of the sink section.



Next, place a front (smaller) rib set against one of the front corners of the sink.



Place the other rear (larger) rib set against the back wall of the sink.



Install the second front and rear rib sets.



Leave a finger-size gap between rib sets.



Partitions

Next, place wash tank partition in the gaps between the front and rear pairs of rib sets. Make sure the partition goes all the way down and is not snagged on the ends of the rib sets.

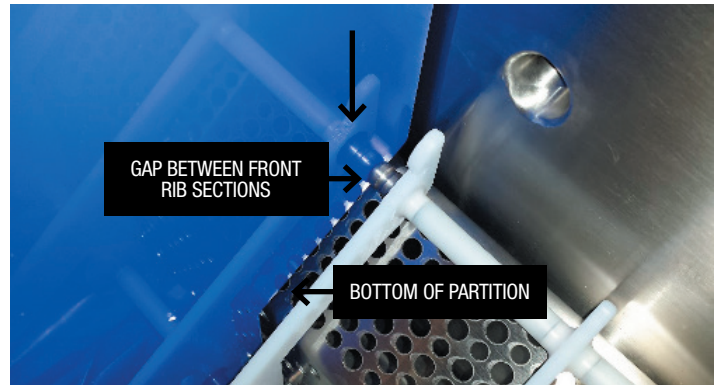
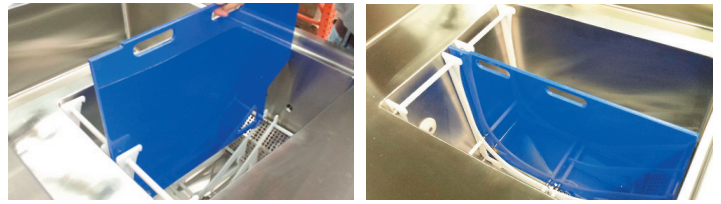

Flow Guides

Once the partition is in place, the flow guides can be installed. Start by positioning a notched end of the flow guide adjacent to the hooks of the front rib set.

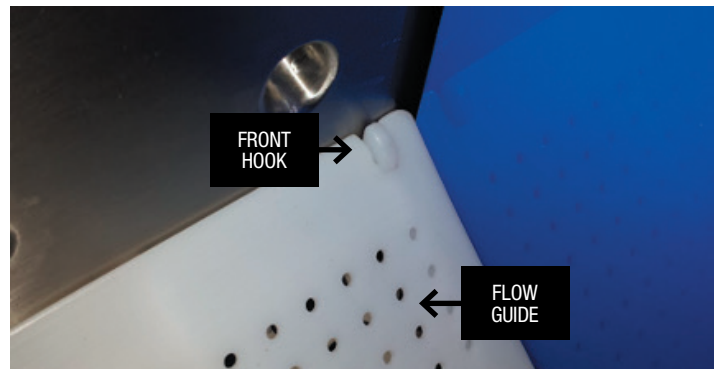

Begin bending the flow guide to the shape of the front rib set, and allow the notches of the flow guide to engage the hooks of the rear rib set.



Continue to push the flow guide down against the rib sets until the notched end of the flow guide nearest you is adjacent to the hooks of the rear rib set.



Repeat the process until both flow guides are in place. Lastly, set the wave guide in place over the rear rib sets.

The wash sink components are now in place, and the Power Prep is ready for use.



FILLING THE POWER PREP

Fill the sink until the water is approximately 1" above water level probe located at the rear wall of the wash tank, but no closer than four inches below the top.

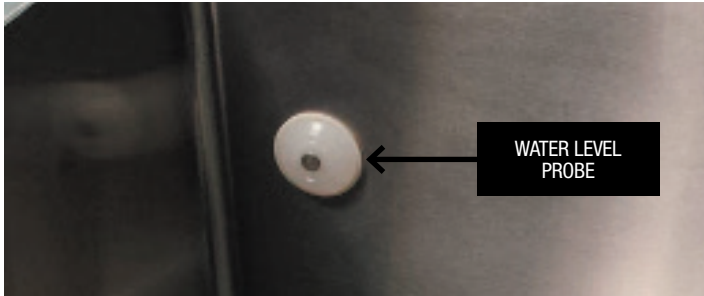

Press and hold the Green button to start the pump.

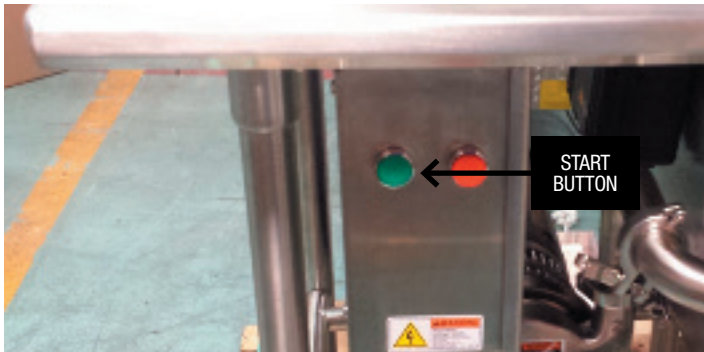

When the pump is running, the water will become turbulent, and a strong back-to-front current will be established.

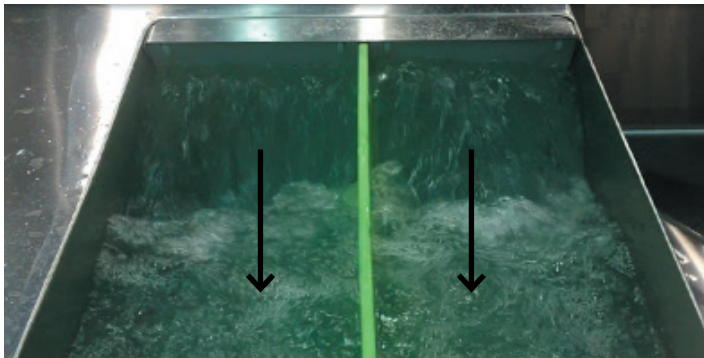

Begin placing product in the Power Prep. Since there are two compartments, you may be tempted to place a different type of product in each one. DO NOT do so --- you risk cross-mixing allergens between different types of product.



After the necessary time for removing the ice covering, the product may be removed by inserting a collection basket. Holding the basket as shown, angle the basket so its leading edge is aligned with the flow in the sink.



As you swing the basket into position, product will begin flowing into the basket.



Lift the full basket out when ready. Always observe safe lifting procedures.



DEGLAZING AND WASHING TIPS

Be sure to follow safe food handling practices.

Conserve water by planning your product deglazing or washing.

Deglazing example:

- Deglaze cooked items first.
- Deglaze shelled items.
- Deglaze raw items last.

- Water should be changed between cooked and raw product deglazing.
- Deglaze only one type of shellfish species at a time in the wash sink. DO NOT mix multiple species at the same time and in the same tank to prevent mixing of allergens.
- Wash more durable items like oranges and apples first, because those items are less likely to soil the water.
- Wash less durable items like lettuce and greens later because of their tendency release small leafy particles into the water.
- Wash items like potatoes and radishes last because of their tendency to carry more soil and other organic materials.
- Consider the possibility of certain foods imparting strong flavor, color or odor.
 - It might be better to wash cut cauliflower before washing blueberries to prevent staining and discoloration.
 - Wash onions, leeks, garlic or other strong flavored foods separately or last to prevent imparting taste or odor to other vegetables and fruit.
 - Consider washing strawberries or seeded items separately or last to prevent the embedding of seeds or discoloration.
- A little planning will reduce the number of washing solution changes resulting in saving time and money.

DRAINING THE WASH SINK

When you have completed the deglazing, turn off the pump by pressing the red button.

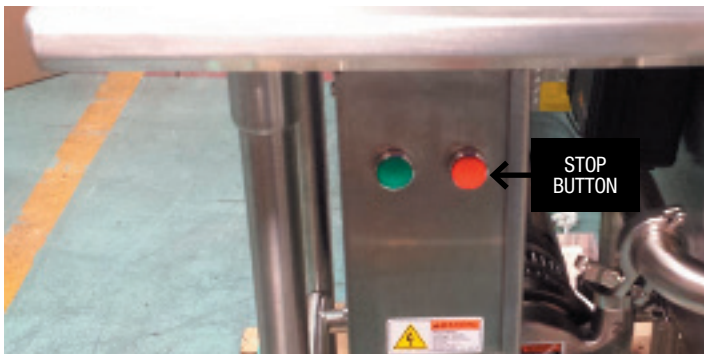

With the product deglazing finished and all product removed, open the drain to empty the tank by turning drain valve handle counter clockwise until handle is aligned in a vertical position.

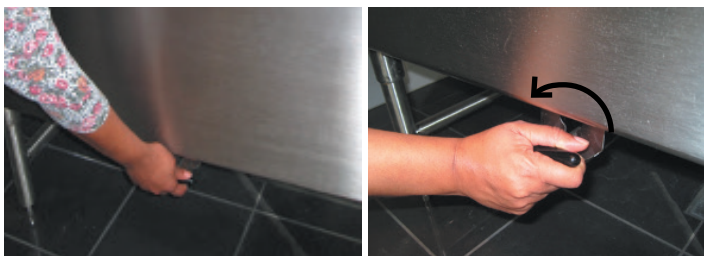

Rinse remaining particles to the drain and remove the strainer to discard the collected waste particles.

Remove each Power Prep component (flow guides, partition, and rib sets) in the reverse order they were assembled. Wash each component to remove all traces of food debris. Position each component so that it dries quickly. Pay particular attention to the flow guides; provide airflow between each of them and do not stack them together wet.

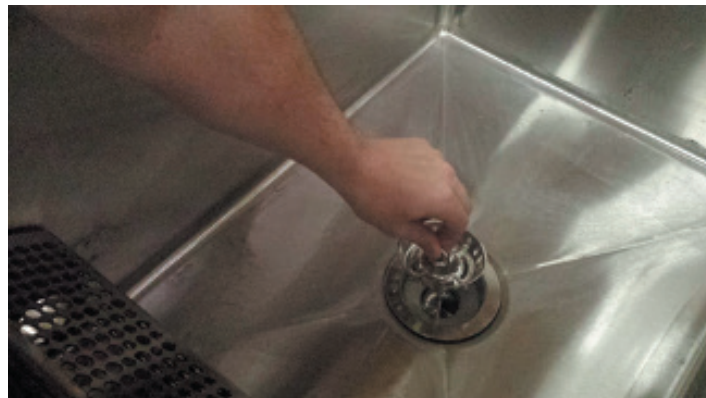

When finished, empty the contents of the filter into a suitable waste container, and wash out the strainer.

PUMP INSTRUCTIONS

PIPING PARTS LIST

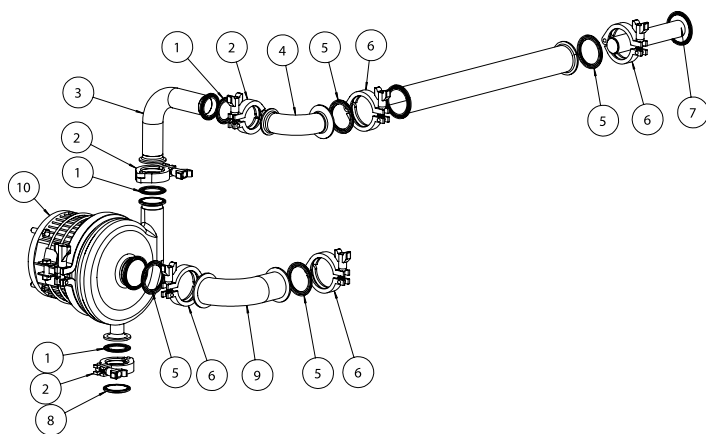

Item	Description	Part No.
1	GASKET, 1-1/2" TRI-CLOVER, NSF	40988
2	CLAMP, 1-1/2", SANITARY	40991
3	ELBOW, 1-1/2" OD INLET	40924
4	ELBOW, REDUCING 90DEG 1-1/2" X 2"	40989
5	GASKET, 2" TRI-CLOVER, NSF	40987
6	CLAMP, 2" SANITARY	40994
7	BALANCER, FLOW	41490
8	END CAP, 1-1/2" SANITARY	41572
9	ELBOW, 2" INTAKE	40925
10	PUMP, SANITARY, CENTRIFUGAL C216	40982

PUMP PARTS LIST

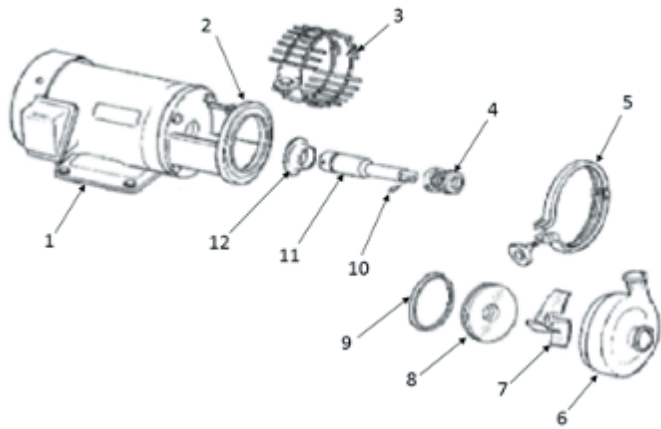

Item	Description	Part No.
1	MOTOR, 3 PHASE	42704
1	MOTOR, 1 PHASE	40983
2	ADAPTER, HOUSING	41687
3	GUARD	41688
4	SEAL, CUP & SPRING ASSEMBLY	41689
5	TRI-CLAMP, 6"	41690
6	PUMP CASING	41691
7	IMPELLER	41692
8	BACK PLATE	41693
9	GASKET	41680
10	RETAINING PIN, IMPELLER	41695
11	STUB SHAFT	41696
12	DEFLECTOR	41697

HAZARDOUS VOLTAGE INSIDE. DISCONNECT POWER BEFORE SERVICING. SERVICE BY TRAINED PERSONNEL ONLY.

KEEP FINGERS OUT OF PORTS.

HOT SURFACES.

PUMP "D" SEAL, CUP & SPRING ASSEMBLY

1. O-ring Seal

Seal, cup & spring assembly



2. Place o-ring inside of the seal



3. Install seal assembly onto stub shaft. Keep notch in cup aligned with the pin on the stub shaft.



TYPE "D" SEAL PARTS BREAKDOWN

Note: Seat seal, cup and spring is provided preassembled.

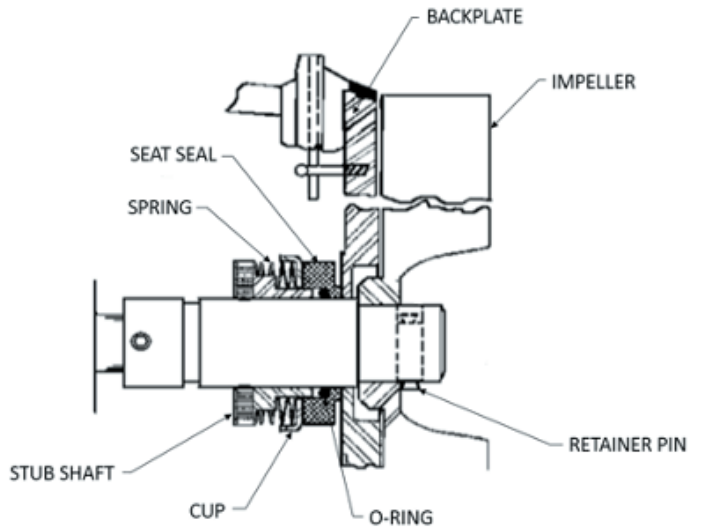
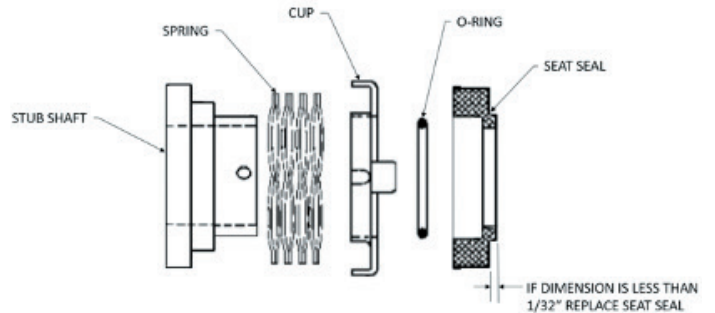

PUMP ASSEMBLY



**HAZARDOUS VOLTAGE INSIDE. DISCONNECT POWER BEFORE SERVICING.
SERVICE BY TRAINED PERSONNEL ONLY.
KEEP FINGERS OUT OF PORTS.**

1. Hold "D" Seal assembly in place



2. Install impeller retainer pin.



3. Hold "D" Seal assembly and install Face Plate onto shaft.



4. Slide on the impeller and push retainer pin over to one side to hold impeller in place.



5. Align the pump casing to the gasket on the face plate. Feel behind the pump casing to ensure the housing is seated evenly against the backing plate gasket.

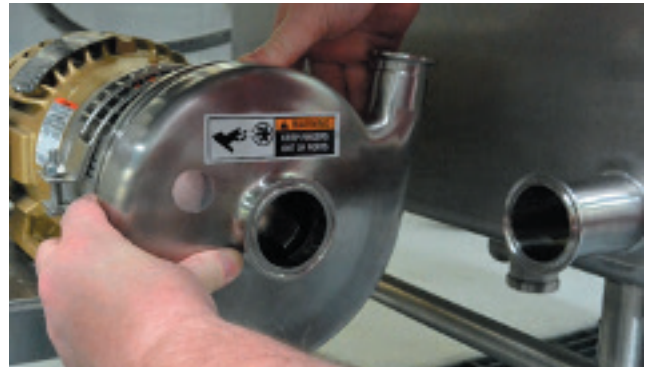

6. Twist the pump so that the outlet is facing straight up, then install the quick clamp.



7. Hold 2" Gaskets into place and install the inlet pipe to the pump.



8. Install 2" quick ("LG" marking) clamps to secure intake piping.



9. The "6" marking on elbow will be near the pump and the "7" will be near the sink

when installed correctly.

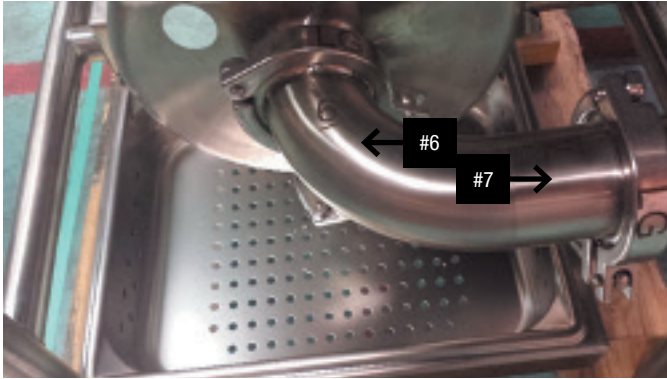

10. Install the 1.5" elbow pipe with 1.5" gaskets and quick clamps ("SM" markings). The "2" marking on elbow will be the connection at the pump when installed correctly.

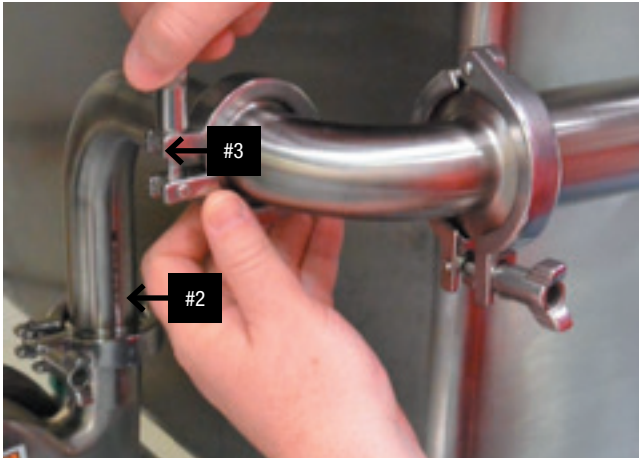

11. Install the 1.5" to 2" elbow using gaskets and quick clamps ("SM" & "LG" markings). The "3" marking on elbow will match "3" at the connection elbow and the "4" will connect to jet manifold when installed correctly.

Note: When installing the piping leave connections loose until all connections have been made. Then tighten them all up at the end of the process. This will allow the pipes to twist or lean making the assembly easier to put together.

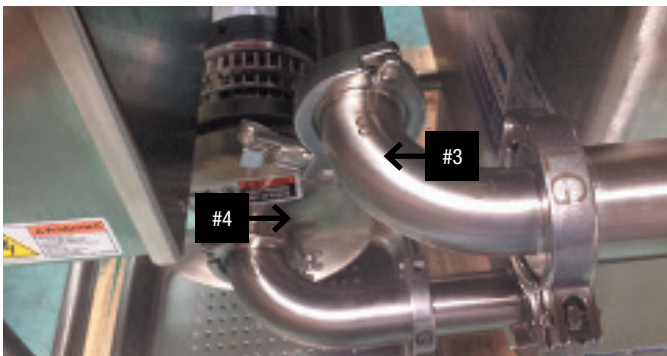

12. Install the Flow Guide ("8" marking) using the 2" gasket and quick clamp ("LG" marking).



WIRING DIAGRAMS

208/240V Single Phase, No Heating

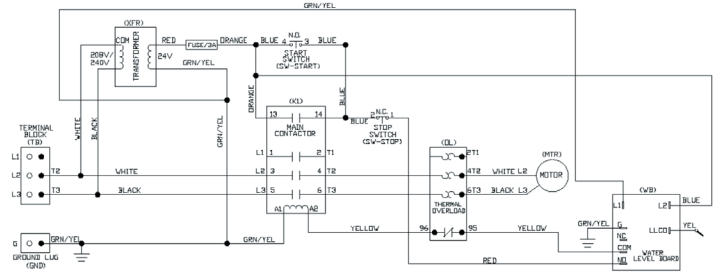

460V Three Phase, No Heating

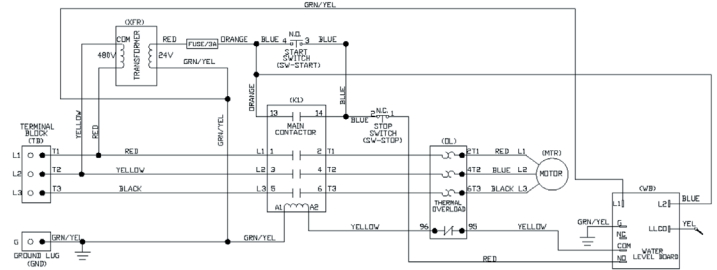

PREVENTATIVE MAINTENANCE



IF THE LIQUID LEVEL SENSOR IS NOT CLEANED REGULARLY, THE MACHINE MAY NOT OPERATE. IT IS ALSO POSSIBLE TO RUN THE PUMP WITHOUT WATER WHICH WILL CAUSE SERIOUS DAMAGE TO THE POWER PREP. RUNNING THE MACHINE WITHOUT WATER IN THE WASH TANK WILL CAUSE DAMAGE THAT IS NOT COVERED BY WARRANTY.



IMPORTANT: TURN OFF THE POWER TO THE UNIT AT THE MAIN BREAKER PRIOR TO PERFORMING THE FOLLOWING TASK!

Your system requires minimal, routine preventive maintenance. As such, the following should be done on a routine basis to ensure that your system remains reliable.

DAILY MAINTENANCE

Clean the liquid level sensor that is located on the rear wall of the wash tank. It is a white plastic disc with a metal center. Clean the sensor face thoroughly. If cleaned regularly, a washcloth and soapy water are all that is required.

MONTHLY MAINTENANCE

About once per month, clean the pump motor fan shroud with a damp, soapy rag. The motor shroud is the "vented" cover located at the end of the motor (closest to the control panel). This will prevent grease and dust from accumulating in the cover's openings, which can obstruct the airflow that cools the motor.

You need not be concerned about greasing the motor bearings, as they are permanently sealed.

There are no other preventive maintenance procedures that you will need to perform on your Power Prep system. If you have any questions regarding the preventive maintenance procedures, please contact the factory at 888-994-7636.

TROUBLESHOOTING



ONLY A LIMITED NUMBER OF TROUBLESHOOTING AND REPAIR PROCEDURES MAY BE PERFORMED BY THE FACILITY OWNER OR MANAGER. ANY TROUBLESHOOTING OR REPAIR THAT REQUIRES THE REMOVAL OF FASTENERS OR THAT ENTAILS ELECTRICAL SERVICE MUST NOT BE ATTEMPTED BY ANYONE OTHER THAN AN AUTHORIZED SERVICE AGENCY. TO OBTAIN THE NAME OF A RECOMMENDED SERVICE AGENT IN YOUR AREA, PLEASE CALL THE POWER SOAK SERVICE DEPARTMENT AT AT 888-994-7636.

SYMPTOM	POSSIBLE CAUSE	REMEDY
Pump motor will not run	Circuit breaker accidentally turned off	Turn breaker on.
	Circuit breaker tripped	Investigate reason for tripping, e.g. damaged wiring, undersized breaker. Contact Power Soak service or an authorized service agency.
	Wall mounted disconnect is turned off	Turn disconnect on
	Motor thermal overload tripped	Investigate reason for overload tripping, e.g. debris stuck in pump impeller. If debris removal requires that you remove any fasteners, contact Power Soak service or an authorized service agency. Once rectified, reset thermal overload by pressing button on bottom of motor junction box.
	Start capacitor defective (single phase motors only)	Replace capacitor. To do this, contact Power Soak service or an authorized service agency.
Pump motor runs, but water flow is inadequate	Motor is running on the wrong voltage	Confirm that the house wiring supply is appropriate for the motor nameplate data. Reconnect motor internal leads according to the motor nameplate instructions. YOU MUST CONTACT Power Soak SERVICE OR AN AUTHORIZED SERVICE AGENCY to make these changes.
	Motor is running the wrong direction	For three phase motors, reverse any two motor leads. For single phase motors, reconnect motor internal leads according to the motor nameplate instructions. YOU MUST CONTACT Power Soak SERVICE OR AN AUTHORIZED SERVICE AGENCY to safely change the rotation.
Unit makes a loud, steady noise when running	Debris caught in the motor's cooling fan	Lock and tag out the electrical power from the unit, remove the motor fan cover, and remove the debris. Replace the fan cover and restore the power. For this task, Contact Power Soak service or an authorized service agency.
	Motor seal running dry	Lock and tag out the electrical power from the unit, remove the motor fan cover, and squirt some low viscosity oil such as WD40 between the fan and the motor end bell. Replace the fan cover and restore the power. Contact Power Soak service or an authorized service agency for service of this nature.
	Debris caught in the pump impeller	Lock and tag out the electrical power from the unit. Remove the pump volute, then remove debris from the impeller and reassemble. Contact Power Soak service or an authorized service agency for this service.

