



# PUMP/FILL STATIONS

## VACUUM CLIPPER MODELS CKCV

CapKold packaging system designed to reduce the air volume of raw meat solids, vegetables and starch products in flexible plastic casings; clip seal them and trim excess casing material, prior to Cook Tank hot water bath cooking and chilling. Can also be used to package fresh produce and prepared foods for convenient handling in transportation and refrigerated storage. Large volume vacuum pump and air operated casing clipper/trimmer standard. The only wet/dry vacuums on the market that can handle liquid products and can be internally sanitized.

### AVAILABLE MODELS:

CKCVE (VERTICAL VACUUM NOZZLE)

(SHOWN TOP RIGHT)

CKCVW (HORIZONTAL VACUUM NOZZLE)

(SHOWN BTM RIGHT)

### STANDARD FEATURES:

- Sturdy Type 304 stainless steel construction
- Easily removable liquids accumulator tank
- Four locking swivel casters

### MODEL CKCVE FEATURES:

Model CKCVE is designed for packaging the full spectrum of products for Cook Tank production and/or package fresh produce, cubed meats, shredded cheese and more.

- Sturdy square tube open base stand
- Compressed air creates a vacuum
- Clipper and vacuum nozzle vertically mounted from support pole, for single motion air extraction and casing clipping (Operator must hold casing upright during operation)
- Air powered clipper with 8' hose provided
- No electrical power required

### MODEL CKCVW FEATURES:

Model CKCVW is specifically designed for high volume meat packaging for Cook Tank production, where operator fatigue is a concern.

- Type 304 stainless steel base cabinet with access door
- Horizontally mounted, retractable vacuum suction nozzle standard
- Heavy duty 1/2 HP large volume vacuum pump standard
- Air powered clipper with 8' hose provided
- Adjustable product support table (Adjusts to height or configuration of food item being packaged)
- 110 VAC single phase electric service required

PROJECT NAME:	
LOCATION:	
ITEM NO:	
QTY:	
MODEL NO:	
AIA NO:	
SIS NO:	
CSI SECTION:	11400



### ADDITIONAL RESOURCES:

[Request A Quote](#)

[Sales Tools](#)

[Find A Rep](#)

## MODEL CKCVE VACUUM CLIPPER

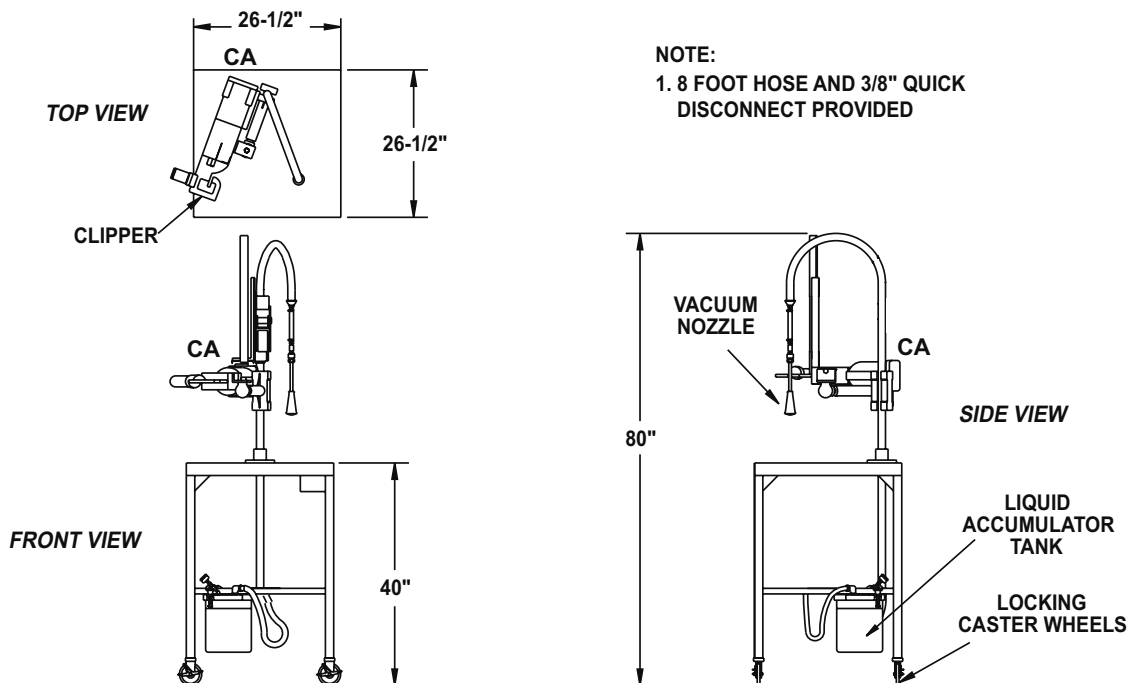

## MODEL CKCVW VACUUM CLIPPER

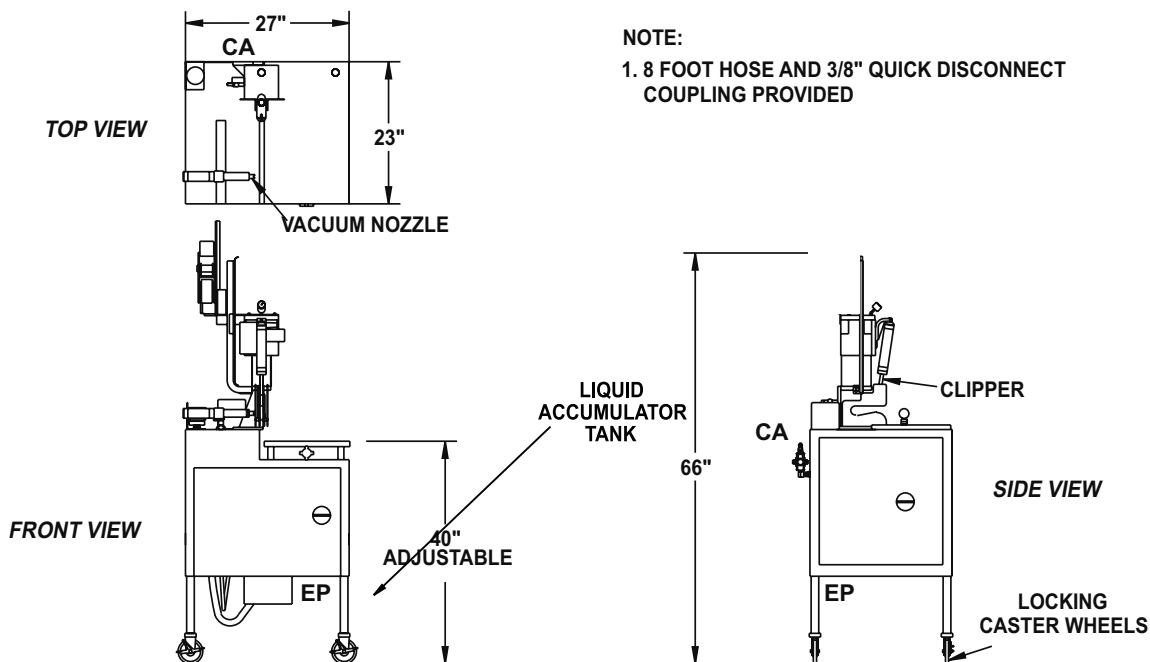

### UTILITY REQUIREMENTS

MODEL	COMPRESSED AIR 90 PSI 60SCFM BURSTS	ELECTRICAL	WEIGHTS (lbs.)	
			SHIPPING	OPERATING
CKVE	8 CFM	NONE	270	240
CKVW	8 CFM	6 AMP	310	280

### UTILITY CONNECTIONS

SYMBOL	CA	EP
DESCRIPTION	COMPRESSED AIR INLET	ELECTRICAL POWER
MODEL		
CKVE	3/8", 8 FOOT HOSE	NONE
CKVW	3/8", 8 FOOT HOSE	110 V, 1 PH

160594