



# SMARTSTEAM PRO

## CONNECTIONLESS STEAMER ELECTRIC MODEL GSSP-CL-5E/ES

Stainless steel, connectionless convection steamer with a self-contained atmospheric 12 KW electric steam generating 3-gallon reservoir.



PROJECT NAME:	
LOCATION:	
ITEM NO:	
QTY:	
MODEL NO:	
AIA NO:	
SIS NO:	
CSI SECTION:	

**SHORT FORM SPEC:** Shall be a Groen SmartSteam Pro model GSSP-CL-5E/ES connectionless electric convection steamer (\_\_\_\_\_volt, \_\_\_\_\_phase). Rear-panel vents. The GSSP-CL-5E is a counter top steamer and the GSSP-CL-5ES comes fully assembled from the factory on a stainless steel stand. Optional double stack stand sold separately with field assembly required. Water-resistant touchscreen control with manual, timed, low-temp, hold modes, and programmable features. Capacity to be (5) 12"x20"x2-1/2" hotel pans. No water or drain lines required, mirrored interior, side-mounted convection fan, 3-gallon water reservoir. Slammable, field-reversible, hands-free stainless steel door latch. Standard 1-year parts and labor warranty with additional 1-year warranty upon completion of a scheduled free Groen startup. 5-year cavity warranty.



### AVAILABLE MODELS:

- GSSP-CL-5E (table top)
- GSSP-CL-5ES (stand-mounted, factory-mounted)

### CONSTRUCTION:

- Stainless steel construction with removable non-louvered side panels
- Rear-panel vents for decreased water/spray ingress
- Stainless steel field-reversible door with continuous hinge and single-piece replaceable seal
- Hands-free door latch provides positive closure when pushed or slammed shut
- Hidden door switch cuts power to blower fan and steam generating reservoir when door is opened
- Pan support racks are stainless steel and easily removed for cleaning
- Removable stainless steel condensate tray located under cavity door
- 5-year cavity warranty
- ASA component control (fan, valve, etc.) allows visibility of component operation on screen
- USB port for service use and firmware updates
- 120 on-hours storage of error code history
- Cord and plug standard (plug and play) except for 208 and 240 volt single phase

**FINISH:** Cabinet exterior and door feature a #3 uniform finish. Cavity interior is polished stainless steel with mirrored finish.

### CONTROLS:

- Water resistant, user-friendly touch screen
- User selected or automatic holding feature after timed cook completes (2 hold modes)
- 10 nameable pan timers
- User selectable door open alert
- Clock
- "+1 minute" button quickly adds to cook time
- User selectable load compensating timer
- Manual, timed, low-temp, and hold steam modes

### PERFORMANCE FEATURES:

- Powerful, side-mounted convection fan increases steam velocity for efficient distribution throughout cavity and between loaded pans (consistent product uniformity and increased cook speeds)
- 2.4 KW of electric power input per 2-1/2" deep steam pan
- Typical heat up is zero to ready in 15 minutes or less

### ATMOSPHERIC STEAM RESERVOIR:

- High-efficiency electric-heated steam generating reservoir provides atmospheric steam to the cavity at a temperature of approximately 145°F-212°F depending on cook mode
- Built-in water sensing system
- Electric heating elements are not immersed in water and are replaceable from the rear

### PAN CAPACITY:

Pan Size/Type	Total
12 x 20 x 1"	10
12 x 20 x 2-1/2"	5
12 x 20 x 4"	3

**INSTALLATION:** Steamer requires 208, 240, or 480 Volt, 3-phase electrical service. All units ship three-phase, and are field convertible to single-phase operation except for 480 volt.

### FREE START-UP:

After the "Free Start-up" is performed, Groen will add an additional 1-year parts and labor warranty.

### OPTIONS/ACCESSORIES:

- Prison Package
- Flanged Foot Kit for Stand
- Caster Kit for Stand
- Heat Shield Kit (field installed)
- 1-Year Warranty Extension
- Pan Rack Assembly Kit (single cavities on stands only)
- Steamer Shelf
- Drain Kit
- Auto Fill (water quality test kit included)
- Trivet
- Double Stack Stand (field installed)

### ADDITIONAL RESOURCES:

- [Request A Quote](#)
- [Sales Tools](#)
- [Find A Rep](#)

**SERVICE CONNECTIONS & NOTES:**

- ① REFER TO ELECTRICAL CHART FOR NEMA TYPE PLUG CONNECTOR. 5 FOOT CORD AND CONNECTOR NOT SHOWN.
- ② STEAM EXHAUST
- ③ CLEARANCES:  
EACH SIDE = 2" [51]  
REAR = 6" [152]

- ④ DIMENSIONS IN BRACKETS [ ] ARE MM.
- ⑤ DO NOT INSTALL STEAMER DIRECTLY ABOVE STEAM VENTING FLOOR DRAINS.
- ⑥ STEAM FREE ZONE: STEAMERS FLOOR DRAIN NOT TO BE LOCATED WITHIN ZONE. ALTERNATE EQUIPMENT THAT DRAIN CAUSING STEAM NOT TO BE DRAINED IN STEAM FREE ZONE.

ELECTRICAL REQUIREMENTS					
VOLTAGE	PHASE	AMPS	MAX. KW	NEMA PLUG	CORD LENGTH
208	1	58	12		
	3	34	12	15-50P	5 FOOT
240	1	50	12		
	3	29	12	15-30P	5 FOOT
480	3	15	12	L16-30P	5 FOOT
ALL UNITS 60Hz					

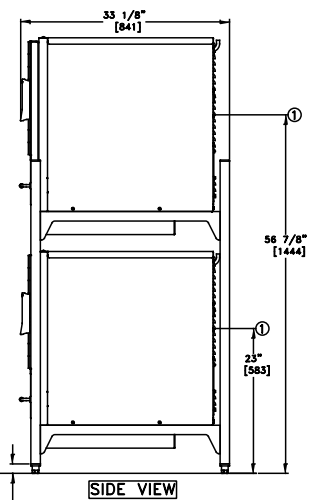
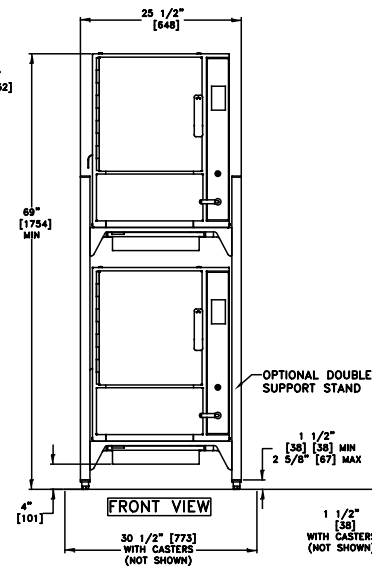
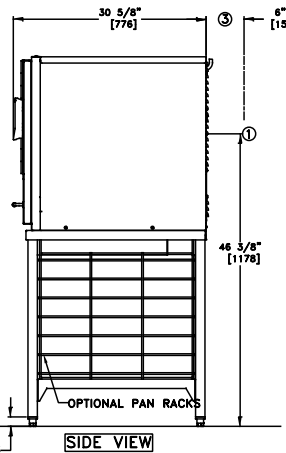
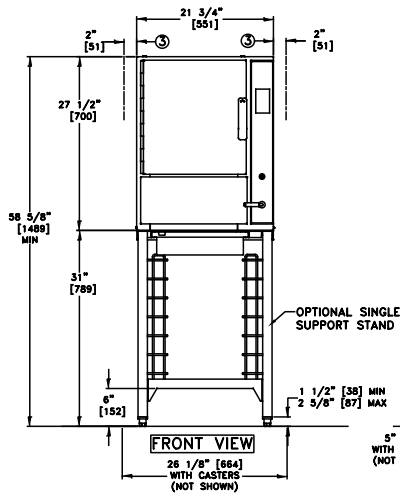
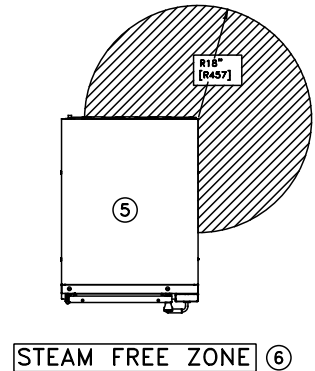
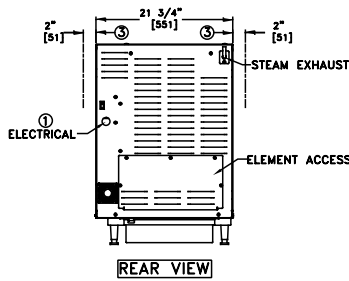
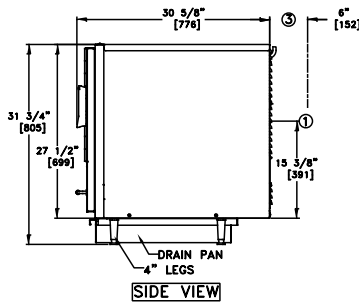
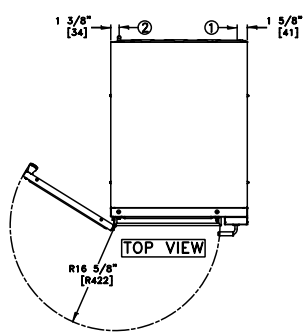

GSSP-CL-5E/SES 179168 REV. A